

POWERED BY



system control

TRISHUL



BUSBAR TRUNKING SYSTEMS



TRISHUL

BUSBAR Trunking Systems

Powering Reliability. Delivering Performance.

BUSBAR TRUNKING SYSTEMS

Contents

1.	Introduction01
2.	Quality Assurance03
3.	Our Infrastructure07
4.	Technical Specifications of Sandwich Busways08
5.	Technical Parameters of Aluminium Sandwich Busways09
6.	Technical Parameters of Copper Sandwich Busways11
7.	Pole Configurations13
8.	Voltage Drop Formula14
9.	Sandwich Busway Elements15
10.	Notes32

Trishul BTS is a premium low-voltage sandwich busbar trunking system engineered and commercialized by SYSTEM CONTROL—a pioneer in MV/HT switchgear manufacturing with over four decades of industry leadership.

Renowned for engineering excellence, dependable performance, and long service life, SYSTEM CONTROL brings the same legacy of quality to Trishul BTS—designed for modern, high-demand power distribution environments.

Engineered for Demanding Applications

Trishul BTS systems are precision-designed, factory-assembled and site-assembled to meet stringent low-voltage power distribution requirements. The product range is type-tested at nationally accredited laboratories like CPRI, Bangalore & ERDA, Vadodara and complies with leading international standards.

Standards & Compliance

- IEC 61439-1 (Low-voltage switchgear and control gear assemblies - General rules) & IEC 61439-6 (Busbar trunking systems - busways)
- IEC 60529 (Ingress Protection)

Applications

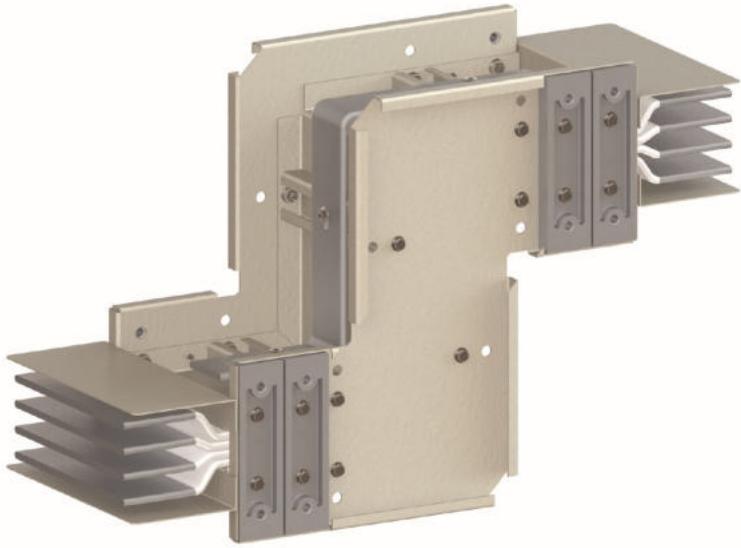

Trishul BTS

is ideally suited for:

- Commercial buildings
- Industrial plants
- Hospitals & healthcare facilities
- Hotels & hospitality projects
- Office complexes
- Data centres & IT parks
- Government & infrastructure projects



Proven Performance | Certified Reliability

The first step towards product quality assurance is the successful type test of the bus bar trunking system. Trishul BTS has successfully passed comprehensive type tests, validating its thermal, electrical, and mechanical robustness:

- Short-Circuit Withstand (STC): 40 kA / 80 kA / 100 kA
- Temperature Rise Tests: 630 A / 1350 A / 2750 A
- Dielectric & Insulation Tests: Power-frequency withstand voltage test & Impulse Voltage Withstand: 8 kV
- Ingress Protection: Up to IP55

These tests ensure **safe, reliable operation under normal and fault conditions.**

Built with Precision Manufacturing

The second step towards product quality assurance is the infrastructure established for manufacturing of these products. Our advanced manufacturing facility is equipped to deliver consistent quality and repeatable performance:

QUALITY ASSURANCE

- CNC busbar fabrication machines
- 160-ton power press
- Busbar welding systems
- Up-stroke busbar cutting machines
- Clean room for conductor insulation wrapping
- High-accuracy contact resistance measurement equipment
- Calibrated torque and fastening tools

Every Trishul **BTS** system reflects **precision engineering and stringent process control**.

Premium Materials. Trusted Sources

The third step towards quality assurance is the choice of raw materials. Only **first-grade raw materials** are used—conductors, insulation films, FRP supports, SMC components, and fasteners—sourced from **reputed, qualified suppliers** with proven consistency and quality.

The result: **long service life, electrical safety, and dependable performance**.

Why Choose Trishul BTS?

- Proven type-tested performance
- Compliance with international standards
- Robust sandwich construction
- Precision manufacturing & quality materials
- Experienced engineering & installation teams
- Reliable after-sales support

CENTRAL POWER RESEARCH INSTITUTE
(Member of ISL)

TEST REPORT

Test Report Number: CPRI/BL/SL/2014/48 Date: 23 September 2020

Name and Address of the Customer: M/s. System Control, Modern Industrial Complex, 375, Anna Nagar, Uthirapattinam, Chennai - 600 031, Tamil Nadu, India.

Name and Address of the Manufacturer: M/s. System Control, Modern Industrial Complex, 375, Anna Nagar, Uthirapattinam, Chennai - 600 031, Tamil Nadu, India.

Particulars of sample tested: 1000V 1500A Switchgear Assembly - 1000V 150A LV Busway

Type: Indoor

Description of test sample: Riser Street 2 of 7

Serial Number: SC21-004A-1500-01

Number of samples tested: One

Date(s) of Test(s): 16 September 2020

CPRI Sample Code No(s): SC2301019

Particulars of tests conducted: Short-circuit withstand strength of main busbars

Test in accordance with Standard Specification: Subclause 10.11.3.3.3 & 10.11.3.3.4 of IEC 61439-1:2011 & IEC 61439-2:2012

Sampling Plan: Not applicable

Customer's Requirement: 40 kA rms for 1.0 s & 80 kA peak for phase busbars

Customer's Representative: Mr. Deepak Anand

Name of the witnessing persons: None

Other than customer's representative: None

Test conducted with address of the laboratory: None

Documents constituting this report (in words): None

Number of Sheets: Two

Number of Drawings: None

Number of Photographs: Two

Number of Test Circuit Diagrams: None

Number of Drawings: Four

Test Engineer: (Signature) Test Engineer

Head of Division: (Signature) Head of Division

Head of Laboratory: (Signature) Head of Laboratory

CENTRAL POWER RESEARCH INSTITUTE
(Member of ISL)

TEST REPORT

Test Report Number: CPRI/BL/SL/2019/19 Date: 18 August 2020

Name and Address of the Customer: M/s. System Control, Modern Industrial Complex, 375, Anna Nagar, Uthirapattinam, Chennai - 600 031, Tamil Nadu, India.

Name and Address of the Manufacturer: M/s. System Control, Modern Industrial Complex, 375, Anna Nagar, Uthirapattinam, Chennai - 600 031, Tamil Nadu, India.

Particulars of sample tested: 1000V 1500A Switchgear Assembly - 1000V 150A LV Busway

Type: Indoor

Description of test sample: Riser Street 2 of 7

Serial Number: SC21-004A-1500-01

Number of samples tested: One

Date(s) of Test(s): 02 May 2020

CPRI Sample Code No(s): SC2301019

Particulars of tests conducted: Temperature rise test

Test in accordance with Standard Specification: Subclause 10.12.3.3.4 of IEC 61439-1:2011 & IEC 61439-2:2012

Sampling Plan: Not applicable

Customer's Requirement: None

Customer's Representative: Mr. Deepak Anand

Name of the witnessing persons: None

Other than customer's representative: None

Test conducted with address of the laboratory: None

Documents constituting this report (in words): None

Number of Sheets: Two

Number of Drawings: None

Number of Photographs: Three

Number of Test Circuit Diagrams: None

Number of Drawings: Four

Test Engineer: (Signature) Test Engineer

Head of Division: (Signature) Head of Division

Head of Laboratory: (Signature) Head of Laboratory

CENTRAL POWER RESEARCH INSTITUTE
(Member of ISL)

TEST REPORT

Test Report Number: CPRI/BL/SL/2019/24 Date: 18 August 2020

Name and Address of the Customer: M/s. System Control, Modern Industrial Complex, 375, Anna Nagar, Uthirapattinam, Chennai - 600 031, Tamil Nadu, India.

Name and Address of the Manufacturer: M/s. System Control, Modern Industrial Complex, 375, Anna Nagar, Uthirapattinam, Chennai - 600 031, Tamil Nadu, India.

Particulars of sample tested: 1000V 1500A Switchgear Assembly - 1000V 150A LV Busway

Type: Indoor

Description of test sample: Riser Street 2 of 7

Serial Number: SC21-004A-1500-01

Number of samples tested: One

Date(s) of Test(s): 28 May 2020 & 27 Jun 2020

CPRI Sample Code No(s): SC2301019

Particulars of tests conducted: Test in accordance with Standard Specification

Test in accordance with Standard Specification: Subclause 10.12.3.3.4 of IEC 61439-1:2011 & IEC 61439-2:2012

Sampling Plan: Not applicable

Customer's Requirement: None

Customer's Representative: Mr. Deepak Anand

Name of the witnessing persons: None

Other than customer's representative: None

Test conducted with address of the laboratory: None

Documents constituting this report (in words): None

Number of Sheets: Two

Number of Drawings: None

Number of Photographs: Two

Number of Test Circuit Diagrams: None

Number of Drawings: Four

Test Engineer: (Signature) Test Engineer

Head of Division: (Signature) Head of Division

Head of Laboratory: (Signature) Head of Laboratory

CENTRAL POWER RESEARCH INSTITUTE
(Member of ISL)

TEST REPORT

Test Report Number: CPRI/BL/SL/2019/16 Date: 8 December 2020

Name and Address of the Customer: M/s. System Control, Modern Industrial Complex, 375, Anna Nagar, Uthirapattinam, Chennai - 600 031, Tamil Nadu, India.

Name and Address of the Manufacturer: M/s. System Control, Modern Industrial Complex, 375, Anna Nagar, Uthirapattinam, Chennai - 600 031, Tamil Nadu, India.

Particulars of sample tested: 1000V 1500A Switchgear Assembly - 1000V 150A LV Busway

Type: Indoor

Description of test sample: Riser Street 2 of 7

Serial Number: SC21-004A-1500-01

Number of samples tested: One

Date(s) of Test(s): 9 October 2020

CPRI Sample Code No(s): SC2301019

Particulars of tests conducted: Temperature rise test

Test in accordance with Standard Specification: Subclause 10.12.3.3.4 of IEC 61439-1:2011 & IEC 61439-2:2012

Sampling Plan: Not applicable

Customer's Requirement: None

Customer's Representative: Mr. Deepak Anand

Name of the witnessing persons: None

Other than customer's representative: None

Test conducted with address of the laboratory: None

Documents constituting this report (in words): None

Number of Sheets: Two

Number of Drawings: None

Number of Photographs: Three

Number of Test Circuit Diagrams: None

Number of Drawings: Four

Test Engineer: (Signature) Test Engineer

Head of Division: (Signature) Head of Division

Head of Laboratory: (Signature) Head of Laboratory

CENTRAL POWER RESEARCH INSTITUTE
(Member of ISL)

TEST REPORT

Test Report Number: CPRI/BL/SL/2019/15 Date: 18 August 2020

Name and Address of the Customer: M/s. System Control, Modern Industrial Complex, 375, Anna Nagar, Uthirapattinam, Chennai - 600 031, Tamil Nadu, India.

Name and Address of the Manufacturer: M/s. System Control, Modern Industrial Complex, 375, Anna Nagar, Uthirapattinam, Chennai - 600 031, Tamil Nadu, India.

Particulars of sample tested: 1000V 1500A Switchgear Assembly - 1000V 150A LV Busway

Type: Indoor

Description of test sample: Riser Street 2 of 7

Serial Number: SC21-004A-1500-01

Number of samples tested: One

Date(s) of Test(s): 02 May 2020

CPRI Sample Code No(s): SC2301019

Particulars of tests conducted: Dielectric properties

Test in accordance with Standard Specification: Subclause 10.12.3.3.4 of IEC 61439-1:2011 & IEC 61439-2:2012

Sampling Plan: Not applicable

Customer's Requirement: None

Customer's Representative: Mr. Deepak Anand

Name of the witnessing persons: None

Other than customer's representative: None

Test conducted with address of the laboratory: None

Documents constituting this report (in words): None

Number of Sheets: Two

Number of Drawings: None

Number of Photographs: Three

Number of Test Circuit Diagrams: None

Number of Drawings: Four

Test Engineer: (Signature) Test Engineer

Head of Division: (Signature) Head of Division

Head of Laboratory: (Signature) Head of Laboratory

CENTRAL POWER RESEARCH INSTITUTE
(Member of ISL)

TEST REPORT

Test Report Number: CPRI/BL/SL/2019/14 Date: 18 August 2020

Name and Address of the Customer: M/s. System Control, Modern Industrial Complex, 375, Anna Nagar, Uthirapattinam, Chennai - 600 031, Tamil Nadu, India.

Name and Address of the Manufacturer: M/s. System Control, Modern Industrial Complex, 375, Anna Nagar, Uthirapattinam, Chennai - 600 031, Tamil Nadu, India.

Particulars of sample tested: 1000V 1500A Switchgear Assembly - 1000V 150A LV Busway

Type: Indoor

Description of test sample: Riser Street 2 of 7

Serial Number: SC21-004A-1500-01

Number of samples tested: One

Date(s) of Test(s): 02 May 2020

CPRI Sample Code No(s): SC2301019

Particulars of tests conducted: Temperature rise test

Test in accordance with Standard Specification: Subclause 10.12.3.3.4 of IEC 61439-1:2011 & IEC 61439-2:2012

Sampling Plan: Not applicable

Customer's Requirement: None

Customer's Representative: Mr. Deepak Anand

Name of the witnessing persons: None

Other than customer's representative: None

Test conducted with address of the laboratory: None

Documents constituting this report (in words): None

Number of Sheets: Two

Number of Drawings: None

Number of Photographs: Three

Number of Test Circuit Diagrams: None

Number of Drawings: Four

Test Engineer: (Signature) Test Engineer

Head of Division: (Signature) Head of Division

Head of Laboratory: (Signature) Head of Laboratory

ELECTRICAL RESEARCH AND DEVELOPMENT ASSOCIATION
(Member of ISL)

TEST REPORT

REPORT NO.: ERDA-2020-030774
DATE OF ISSUE: 03.02.2020

NAME AND ADDRESS OF CUSTOMER: SYSTEM CONTROL, 375, ANNA NAGAR INDUSTRIAL COMPLEX, ANNA NAGAR, UTHIRAPATTINAM, CHENNAI - 600 031, TAMIL NADU, INDIA.

DATE OF SAMPLE RECEIVED: 23.03.2020
DATE OF TESTING: 27.01.2020 to 29.01.2020

SAMPLE DESCRIPTION: 1500V, 1500A AC LV SWITCHGEAR BUSWAYS (Riser Street 2 of 7)

SAMPLE IDENTIFICATION: ERDA SAMPLE CODE No.: ERDA-0006637

TYPE DESIGNATION: INDOOR/SWITCHGEAR BUSWAY

DRAWING No.: As per SHEET 2 OF 5

TEST SPECIFICATIONS: IEC 61439-1:2011 & IEC 61439-2:2012

TESTED BY: Mr. DEEPAK ANAND (DESIGN MANAGER)

TESTED AT: CPRI, CHENNAI

TESTED ON: 27.01.2020

TESTED BY: (Signature) Test Engineer

TESTED AT: (Signature) Head of Division

TESTED ON: (Signature) Head of Laboratory

Certificate of Registration

This certificate has been awarded to:

System Control

375, Anna Nagar, Marayanaar, Salem (TK), Salem, Tamilnadu, 696022, India

In recognition of the organization's Quality Management System which complies with:

ISO 9001:2015

The scope of activities covered by this certificate is defined below:

Design, Develop and Manufacture of Medium and High Rating Switch Gears

Approved by: (Signature) Head of Division

Approved by: (Signature) Head of Laboratory

Approved by: (Signature) Head of Division

Approved by: (Signature) Head of Laboratory

QUALITY ASSURANCE



TYPE TESTED AT CPRI | ERDA

OUR INFRASTRUCTURE



BUSBAR PROCESSING MACHINE

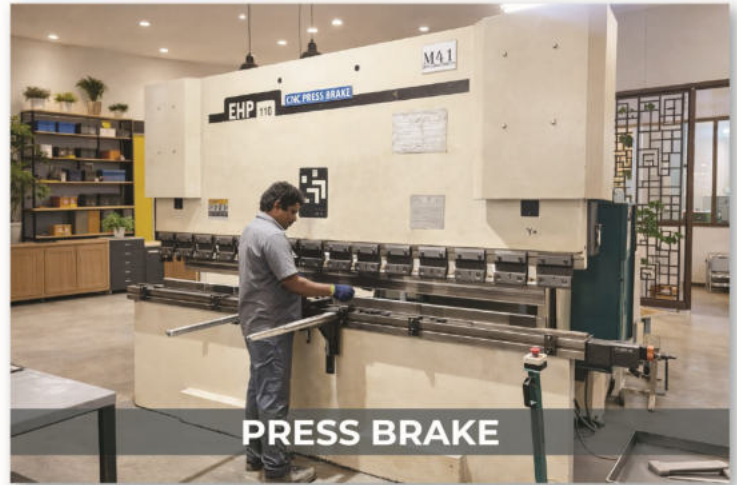

PRESS BRAKE



BUSWAYS ASSEMBLY



TURRET PUNCHING PRESS



WELDING MACHINE



POWER PRESS



BUSBAR CUTTING MACHINE

TECHNICAL SPECIFICATIONS

SANDWICH BUSWAYS

Parameter	Specification
Busbar Construction	Sandwich Type
Current Ratings	Copper: 630 A – 6300 A Aluminium: 400 A – 5000 A
Busbar Material (Phase / Neutral)	Copper (ETP Grade) / Aluminium (High Conductivity)
Busbar Material (Earth)	Copper / Aluminium
Insulation System	Polyester + Aramid (High-dielectric composite laminate)
Busbar Configurations	3 Phase + Integral Ground Earth. 3 Phase + 100% Neutral + Integral Ground Earth. 3 Phase + 100% Neutral + 50% Internal Earth + Integral Ground Earth. 3 Phase + 100% Neutral + 100% Internal Earth + Integral Ground Earth. 3 Phase + 200% Neutral + Integral Ground Earth.
Rated Frequency	50 Hz / 60 Hz
Rated Operational Voltage (U _e)	1000V AC
Rated Insulation Voltage (U _i)	1000V AC
Rated Impulse Withstand Voltage (U _{imp})	8 kV
Joint Type	Uniblock Joint Assembly
Enclosure Material	Galvanized Iron (GI)
Enclosure Surface Coating	Powder Coated (RAL 7032)
Compliance Standard	IEC 61439 (1 & 6)
Certification Authority	CPRI, ERDA
Tap-off / Plug-in Ratings	32A – 630A
Seismic Qualification	Suitable for Zone-5 Seismic Region
Degree of Protection	IP54 (Plug-in Type) IP55 (Feeder Type) IP65 available upon request
Service Condition	Ambient Temperature: -15°C to 50°C Relative Humidity: 95% or below

TECHNICAL PARAMETERS

ALUMINIUM SANDWICH BUSWAYS

Rated Current	I	Amps	400A	500A	630A
Product Code		-	TSA400	TSA500	TSA630
Busbar Dimensions per Phase	W x T	(mm x mm)	50x6	60x6	80x6
No of Stacks		Nos	1	1	1
Overall Height of Busbar Trunking		mm	85	95	115
Approximate Weight of Busways					
3 Phase + Integral Ground Earth		Kg/mtr	9.8	10.6	12.3
3 Phase + 100% Neutral + Integral Ground Earth		Kg/mtr	10.6	11.6	13.6
3 Phase + 100% Neutral + 50% Internal Earth + Integral Ground Earth		Kg/mtr	11.0	12.1	14.2
3 Phase + 100% Neutral + 100% Internal Earth + Integral Ground Earth		Kg/mtr	11.4	12.6	14.9
3 Phase + 200% Neutral + Integral Ground Earth		Kg/mtr	11.4	12.6	14.9
Short Circuit Capacity					
Rated 3 Phase RMS Short Time Current for 1 Second	I _{cw}	kA	25	32	40
Rated 3 Phase Peak Short Time Current	I _{pk}	kA	53	67	84
Rated 1 Phase RMS Short Time Current for 1 Second	I _{cw}	kA	15	19	24
Rated 1 Phase Peak Short Time Current	I _{pk}	kA	32	40	50
Electrical Characteristics for Phase Conductor at 50 Hz					
AC Resistance at 20 °C	R ₂₀	mΩ/mtr	0.0991	0.0832	0.0635
AC Resistance at Thermal Condition	R _t	mΩ/mtr	0.1269	0.1067	0.0814
Reactance	X	mΩ/mtr	0.0396	0.0336	0.0258
Impedance	Z	mΩ/mtr	0.1328	0.1116	0.0852
Voltage Drop on Full Load at end of Busbar Trunking (0.7 p.f. lag)	ΔU	mV/mtr/A	0.2028	0.1707	0.1305
Voltage Drop on Full Load at end of Busbar Trunking (0.8 p.f. lag)	ΔU	mV/mtr/A	0.2169	0.1825	0.1394
Voltage Drop on Full Load at end of Busbar Trunking (0.9 p.f. lag)	ΔU	mV/mtr/A	0.2276	0.1914	0.1462
Voltage Drop on Full Load at end of Busbar Trunking (1.0 p.f.)	ΔU	mV/mtr/A	0.2197	0.1845	0.1408
Electrical Characteristics for Phase Conductor at 60 Hz					
AC Resistance at 20 °C	R ₂₀	mΩ/mtr	0.0995	0.0871	0.6411
AC Resistance at Thermal Condition	R _t	mΩ/mtr	0.1276	0.1074	0.0821
Reactance	X	mΩ/mtr	0.0476	0.0404	0.0311
Impedance	Z	mΩ/mtr	0.1359	0.1186	0.0878
Voltage Drop on Full Load at end of Busbar Trunking (0.7 p.f. lag)	ΔU	mV/mtr/A	0.2133	0.1852	0.1381
Voltage Drop on Full Load at end of Busbar Trunking (0.8 p.f. lag)	ΔU	mV/mtr/A	0.2259	0.1965	0.1461
Voltage Drop on Full Load at end of Busbar Trunking (0.9 p.f. lag)	ΔU	mV/mtr/A	0.2345	0.2043	0.1514
Voltage Drop on Full Load at end of Busbar Trunking (1.0 p.f.)	ΔU	mV/mtr/A	0.2206	0.1931	0.1421

TECHNICAL PARAMETERS

800A	1000A	1250A	1350A	1600A	2000A	2500A	2750A	3200A	4000A	5000A
TSA800	TSA1000	TSA1250	TSA1350	TSA1600	TSA2000	TSA2500	TSA2750	TSA3200	TSA4000	TSA5000
100x6	125x6	150x6	175x6	200x6	230x6	150x6	175x6	200x6	230x6	200x6
1	1	1	1	1	1	2	2	2	2	3
135	160	185	210	235	265	370	420	470	530	740
14.0	16.1	18.3	20.4	22.5	25.1	36.0	40.9	45.8	51.6	76.4
15.6	18.1	20.7	23.2	25.7	28.8	40.9	46.6	52.3	59.1	86.1
16.4	19.1	21.9	24.6	27.3	30.7	43.3	49.4	55.5	62.8	91.0
17.2	20.1	23.1	26.0	28.9	32.5	45.8	52.3	58.8	66.6	95.8
17.2	20.1	23.1	26.0	28.9	32.5	45.8	52.3	58.8	66.6	95.8
50	65	65	80	80	80	100	100	100	100	120
105	143	143	176	176	176	220	220	220	220	264
30	39	39	48	48	48	60	60	60	60	72
63	86	86	106	106	106	132	132	132	132	168
0.0517	0.0418	0.0353	0.0305	0.0269	0.0236	0.0185	0.0161	0.0143	0.0126	0.0111
0.0662	0.0537	0.0452	0.0391	0.0345	0.0303	0.0237	0.0206	0.0183	0.0162	0.0128
0.0296	0.0169	0.0142	0.0122	0.0107	0.0094	0.0072	0.0062	0.0054	0.0047	0.0036
0.0724	0.0561	0.0473	0.0409	0.0361	0.0316	0.0247	0.0215	0.0191	0.0168	0.0146
0.1168	0.0858	0.0723	0.0624	0.0551	0.0483	0.0376	0.0327	0.0289	0.0254	0.0217
0.1225	0.0917	0.0774	0.0668	0.0588	0.0516	0.0403	0.0351	0.0311	0.0272	0.0234
0.1255	0.0962	0.0812	0.0701	0.0618	0.0542	0.0423	0.0368	0.0326	0.0287	0.0249
0.1146	0.0927	0.0783	0.0676	0.0542	0.0523	0.0411	0.0357	0.0317	0.0279	0.0246
0.0522	0.0423	0.0313	0.0308	0.0272	0.0239	0.0188	0.0164	0.0145	0.0129	0.0102
0.0669	0.0542	0.0402	0.0395	0.0349	0.0307	0.0241	0.0211	0.0186	0.0165	0.0131
0.0251	0.0203	0.0171	0.0147	0.0129	0.0113	0.0087	0.0074	0.0065	0.0057	0.0044
0.0714	0.0436	0.0435	0.0421	0.0371	0.0326	0.0255	0.0222	0.0196	0.0174	0.0137
0.1121	0.0908	0.0697	0.0661	0.0582	0.0511	0.0399	0.0346	0.0305	0.0271	0.0213
0.1187	0.0961	0.0733	0.0699	0.0616	0.0541	0.0424	0.0368	0.0325	0.0288	0.0227
0.1231	0.0754	0.0754	0.0726	0.0641	0.0562	0.0441	0.0383	0.0338	0.03001	0.0237
0.1157	0.0938	0.0694	0.0683	0.0603	0.0531	0.0417	0.0364	0.0321	0.0286	0.0226

ALUMINIUM SANDWICH BUSWAYS

TECHNICAL PARAMETERS

COPPER SANDWICH BUSWAYS

Rated Current	I	Amps	630A	800A
Product Code		-	TSC630	TSC800
Busbar Dimensions per Phase	W x T	(mm × mm)	40x6	50x6
No of Stacks		Nos	1	1
Overall Height of Busbar Trunking		mm	75	85
Approximate Weight of Busways				
3 Phase + Integral Ground Earth		Kg/mtr	13.1	15.3
3 Phase + 100% Neutral + Integral Ground Earth		Kg/mtr	15.2	18.0
3 Phase + 100% Neutral + 50% Internal Earth + Integral Ground Earth		Kg/mtr	16.3	19.3
3 Phase + 100% Neutral + 100% Internal Earth + Integral Ground Earth		Kg/mtr	17.3	20.7
3 Phase + 200% Neutral + Integral Ground Earth		Kg/mtr	17.3	20.7
Short Circuit Capacity				
Rated 3 Phase RMS Short Time Current for 1 Second	I _{cw}	kA	40	50
Rated 3 Phase Peak Short Time Current	I _{pk}	kA	84	105
Rated 1 Phase RMS Short Time Current for 1 Second	I _{cw}	kA	24	30
Rated 1 Phase Peak Short Time Current	I _{pk}	kA	50	63
Electrical Characteristics for Phase Conductor at 50 Hz				
AC Resistance at 20 °C	R ₂₀	mΩ/mtr	0.0759	0.0615
AC Resistance at Thermal Condition	R _t	mΩ/mtr	0.0967	0.0784
Reactance	X	mΩ/mtr	0.0459	0.0396
Impedance	Z	mΩ/mtr	0.1074	0.0881
Voltage Drop on Full Load at end of Busbar Trunking (0.7 p.f. lag)	ΔU	mV/mtr/A	0.1746	0.1444
Voltage Drop on Full Load at end of Busbar Trunking (0.8 p.f. lag)	ΔU	mV/mtr/A	0.1823	0.1502
Voltage Drop on Full Load at end of Busbar Trunking (0.9 p.f. lag)	ΔU	mV/mtr/A	0.1861	0.1526
Voltage Drop on Full Load at end of Busbar Trunking (1.0 p.f.)	ΔU	mV/mtr/A	0.1683	0.1363
Electrical Characteristics for Phase Conductor at 60 Hz				
AC Resistance at 20 °C	R ₂₀	mΩ/mtr	0.0763	0.0619
AC Resistance at Thermal Condition	R _t	mΩ/mtr	0.0973	0.0791
Reactance	X	mΩ/mtr	0.0551	0.0476
Impedance	Z	mΩ/mtr	0.1121	0.0924
Voltage Drop on Full Load at end of Busbar Trunking (0.7 p.f. lag)	ΔU	mV/mtr/A	0.1886	0.1549
Voltage Drop on Full Load at end of Busbar Trunking (0.8 p.f. lag)	ΔU	mV/mtr/A	0.1926	0.1593
Voltage Drop on Full Load at end of Busbar Trunking (0.9 p.f. lag)	ΔU	mV/mtr/A	0.1938	0.1594
Voltage Drop on Full Load at end of Busbar Trunking (1.0 p.f.)	ΔU	mV/mtr/A	0.1692	0.1372

TECHNICAL PARAMETERS

1000A	1250A	1600A	2000A	2500A	3200A	4000A	5000A	6300A
TSC1000	TSC1250	TSC1600	TSC2000	TSC2500	TSC3200	TSC4000	TSC5000	TSC6300
70x6	100x6	125x6	175x6	230x6	125x6	175x6	230x6	175x6
1	1	1	1	1	2	2	2	3
105	135	160	210	265	320	420	530	630
19.1	25.2	30.0	39.9	50.7	60.6	80.0	102.9	121.1
22.8	30.5	36.7	49.2	63.0	73.9	98.7	127.5	149.1
24.7	33.2	40.0	53.9	69.1	80.6	108.0	139.8	163.1
26.5	35.8	43.4	58.5	75.3	87.3	117.4	152.1	177.1
26.5	35.8	43.4	58.5	75.3	87.3	117.4	152.1	177.1
50	65	80	80	80	100	100	100	100
105	143	176	176	176	220	220	220	220
30	39	48	48	48	60	60	60	60
63	86	106	106	106	132	132	132	132
0.0449	0.0325	0.0263	0.0193	0.0151	0.0141	0.0103	0.0081	0.0072
0.0573	0.0414	0.0336	0.0246	0.0192	0.0178	0.0132	0.0103	0.0092
0.0292	0.0209	0.0169	0.0122	0.0094	0.0086	0.0062	0.0047	0.0041
0.0644	0.0465	0.0376	0.02755	0.0214	0.0199	0.0145	0.0113	0.0101
0.1058	0.0763	0.0617	0.0451	0.0351	0.0325	0.0252	0.0184	0.0162
0.1101	0.0794	0.0642	0.0469	0.0366	0.0339	0.0247	0.0193	0.0171
0.1116	0.0806	0.0652	0.0477	0.0372	0.0346	0.0237	0.0197	0.0175
0.0995	0.0721	0.0583	0.0428	0.0335	0.0313	0.0228	0.0181	0.0161
0.0454	0.0328	0.0266	0.0196	0.0153	0.0142	0.0105	0.0082	0.0076
0.0579	0.0418	0.0341	0.0251	0.0195	0.0181	0.0134	0.0105	0.0097
0.0351	0.0252	0.0203	0.0147	0.0113	0.0104	0.0075	0.0057	0.0051
0.0678	0.0489	0.0396	0.0291	0.0226	0.0209	0.0153	0.0119	0.0109
0.1139	0.0821	0.0664	0.0486	0.0377	0.0349	0.0256	0.0198	0.0181
0.1169	0.0844	0.0683	0.0501	0.0389	0.0361	0.0264	0.0205	0.0188
0.1171	0.0845	0.0684	0.0502	0.0391	0.0362	0.0266	0.0207	0.0191
0.1007	0.0727	0.0591	0.0435	0.0339	0.0315	0.0233	0.0182	0.0168

COPPER SANDWICH BUSWAYS

POLE CONFIGURATIONS

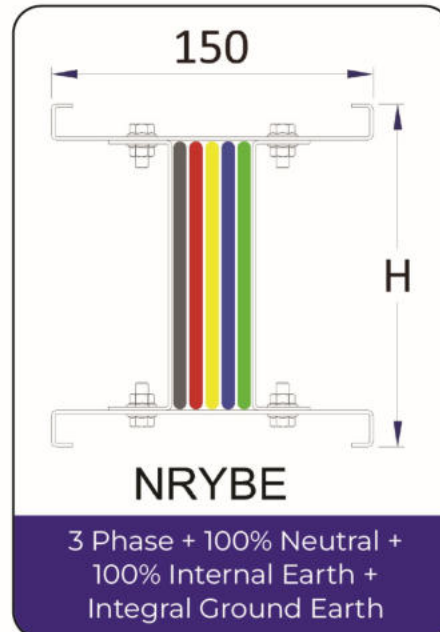
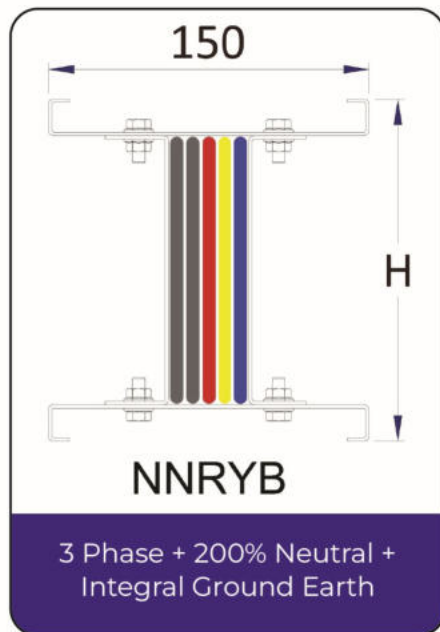
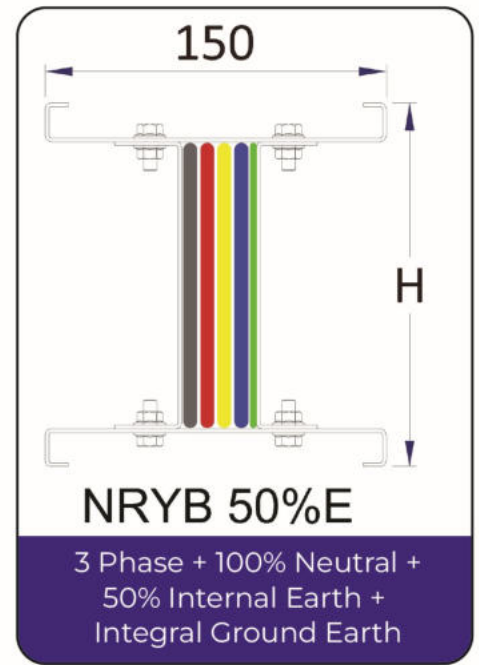
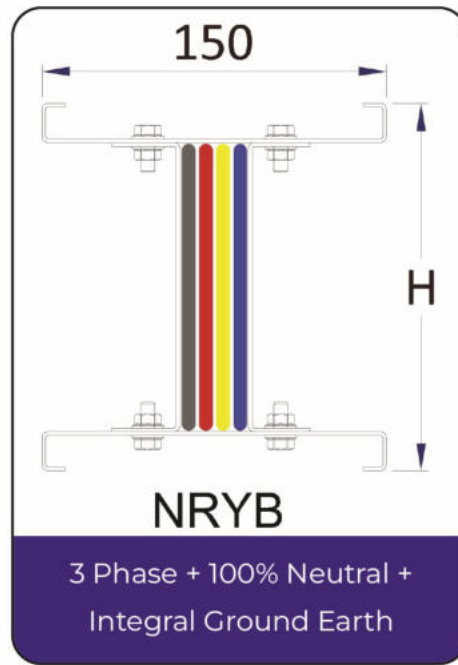
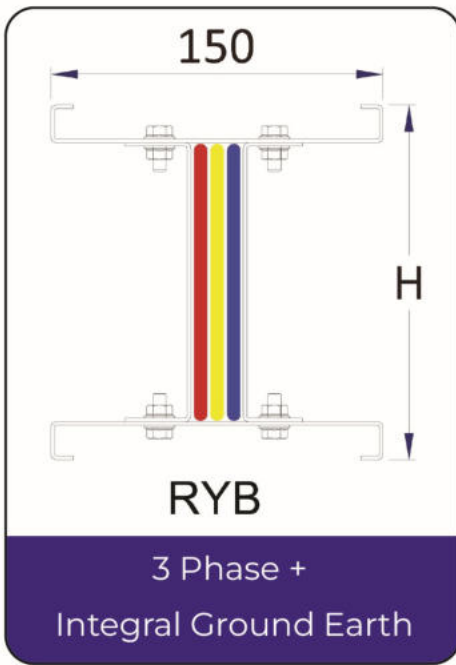

VOLTAGE DROP FORMULA

The voltage drop in a three-phase Sandwich busbar trunking system is calculated using the following formula:

$$u = k \times \sqrt{3} (R \cos \varphi + X \sin \varphi) I_{\beta} L$$

Where

Symbol	Description	Unit
u	Composite voltage drop of the system	V
R	Mean resistance of conductors (IEC 61439-6, Clause 5.101)	Ω/m
X	Mean reactance of conductors (IEC 61439-6, Clause 5.101)	Ω/m
I_{β}	Design current of the circuit	A
L	Length of the busbar trunking system	m
$\cos \varphi$	Load power factor	—
$\sin \varphi$	Reactive power factor	—
k	Load distribution factor	—

Load Distribution Factor (k)

k = 1.0 – Load concentrated at the end of the busbar run

Notes

- Applicable to three-phase AC busbar trunking systems
- Resistance and reactance values are mean values per metre
- Calculation method as per IEC 61439-6
- Suitable for Copper and Aluminium Sandwich Busbar Systems

1. Standard Feeder

Standard Feeder length can be manufactured up to maximum length of 3000mm and minimum length of 500mm

Busway Length (mm)			SS	Single Stack
L	Min	Max	DS	Double Stack
	500	3000	TS	Triple Stack

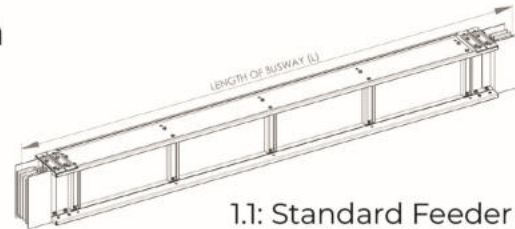

1.1: Standard Feeder for SS

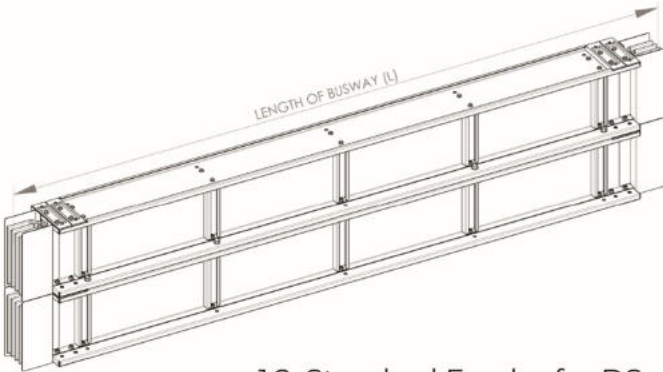

1.2: Standard Feeder for DS

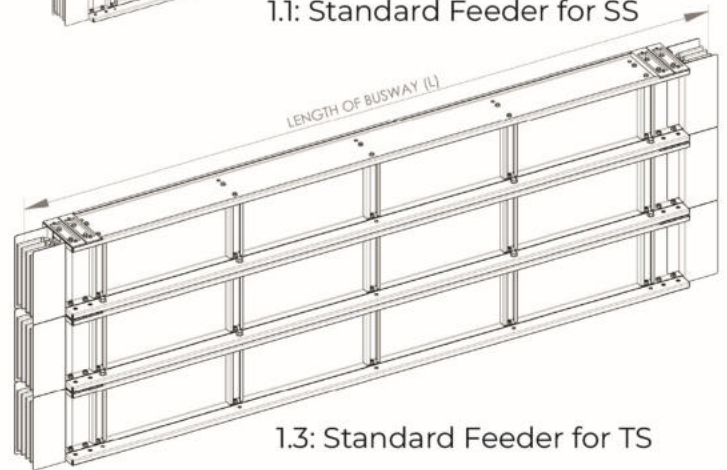

1.3: Standard Feeder for TS

2. Plug-in Feeder

Feeder lengths with Tap-off slots. Supplied with maximum 3 plug-in points (PIP) in a standard 3m length. Can be run vertically or horizontally.

Plug in Feeder Length (mm)		
L	Min	Max
	1200	3000

2.1: Plug-in Feeder – SS

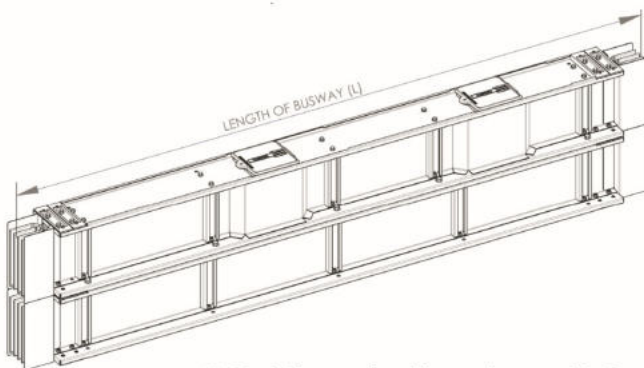
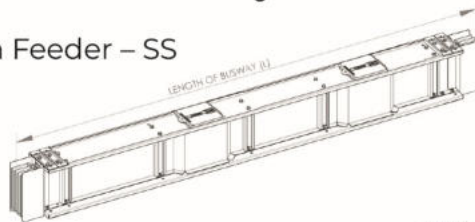

2.2: Plug-in Feeder – DS

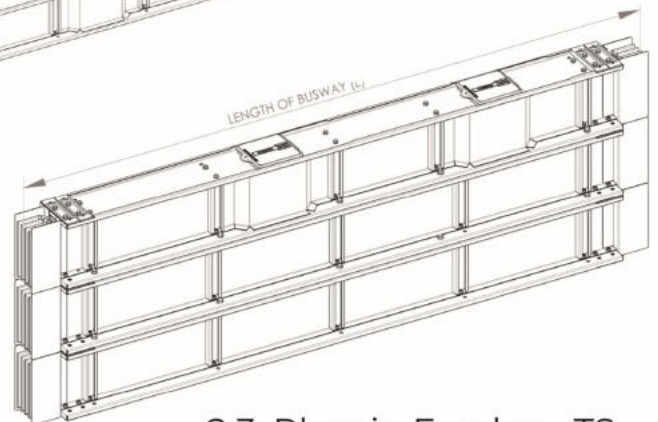

2.3: Plug-in Feeder – TS

SANDWICH BUSWAY ELEMENTS

3. Joint

Monoblock Joint System used for joining two busway Elements.

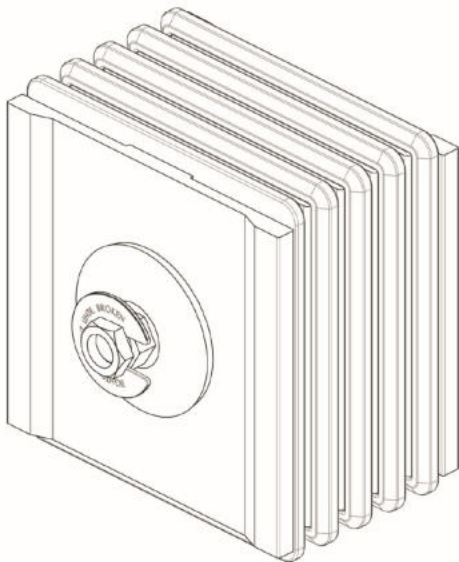

3.1: Joint

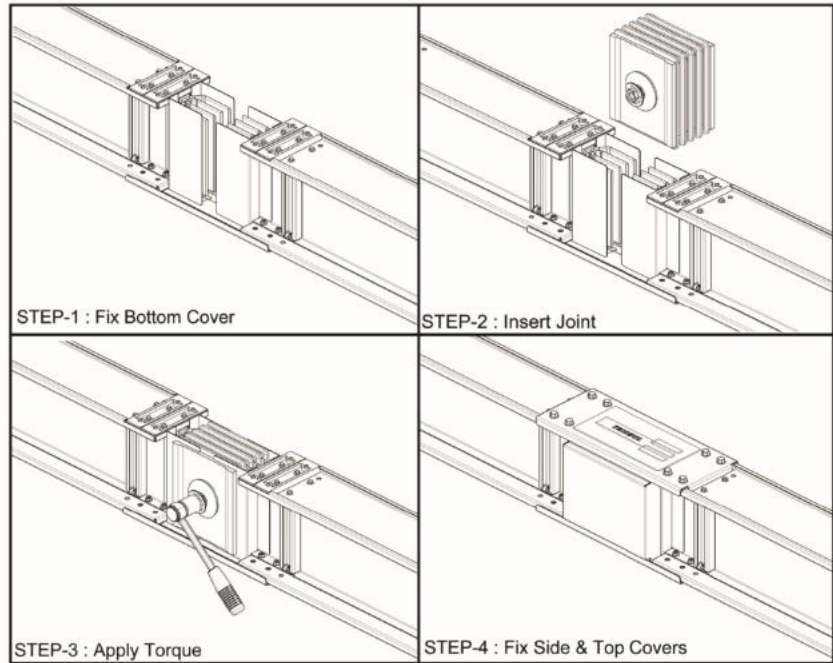

3.2: Joint Assembly Procedure

4. Edgewise Elbow

Used for 90° turn when the busbar route is running on its edge. Can be Edgewise Left or Right.

Standard Size (mm)	
A	500
B	500

Min & max arm Dimensions (mm)				
Stack	A		B	
	Min	Max	Min	Max
SS	400	1000	400	1000
S	400	1000	400	1000
TS	400	1000	400	1000

4.2: Edgewise Elbow - DS

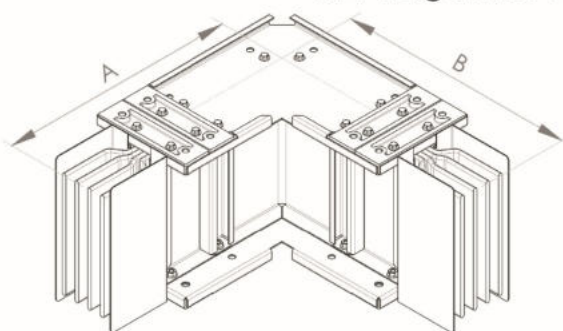

4.1: Edgewise Elbow - SS

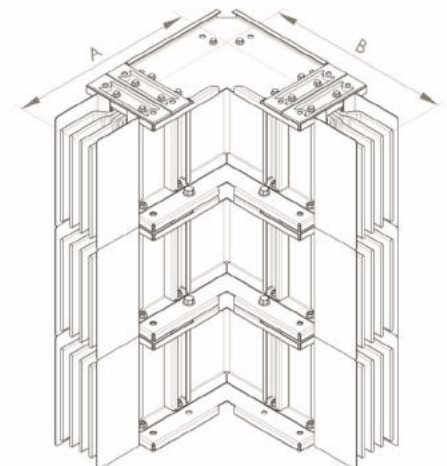
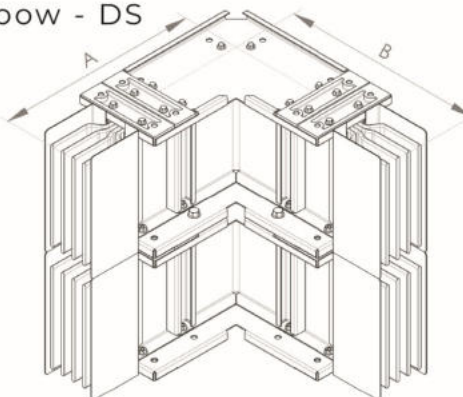

4.3: Edgewise Elbow - TS

5. Flatwise Elbow

Used for 90° turn when the busbar route is running flat. Can be Flatwise Up or Down.

Standard Size (mm)		
Stack	A	B
SS	400	400
DS	500	500
TS	600	600

Min & Max arm Dimensions (mm)				
Stack	A		B	
	Min	Max	Min	Max
SS	400	1000	400	1000
DS	500	1000	500	1000
TS	600	1000	600	1000

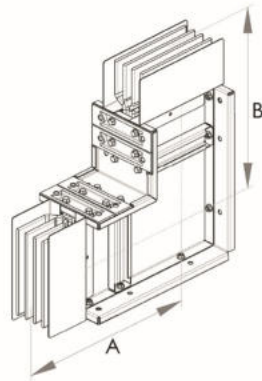

5.1: Flatwise Elbow- SS

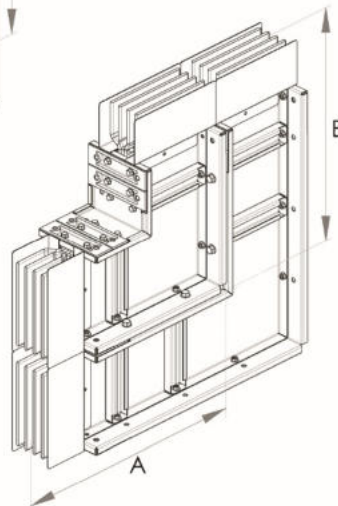

5.2: Flatwise Elbow- DS

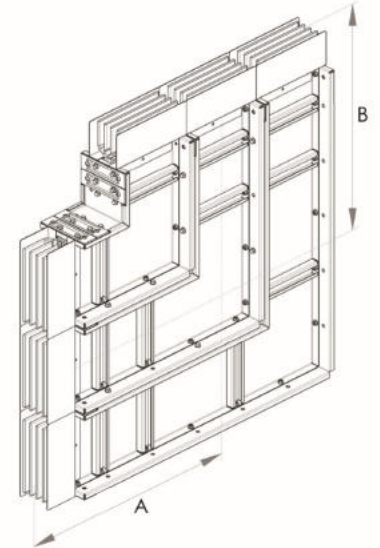

5.3: Flatwise Elbow- TS

6. Edgewise Offset Elbow

Combines two edgewise elbows into one unit for offset routing.

6.1: Edgewise Offset Elbow - SS

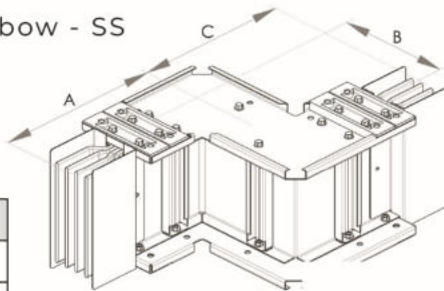

6.3: Edgewise Offset Elbow - TS

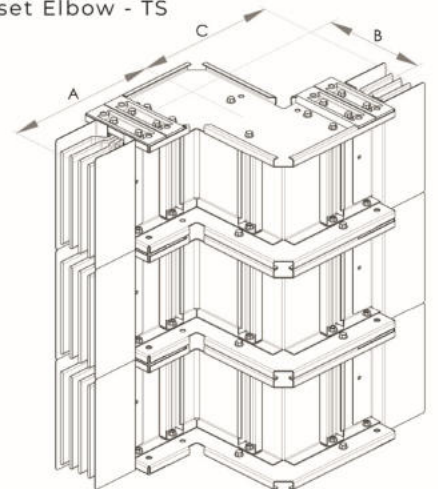

Standard Size (mm)	
A	B
500	500
500	500
500	500

Min & max arm Dimensions (mm)						
Stack	A		B		C	
	Min	Max	Min	Max	Min	Max
SS	400	800	200	800	400	800
DS	400	800	200	800	400	800
TS	400	800	200	800	400	800

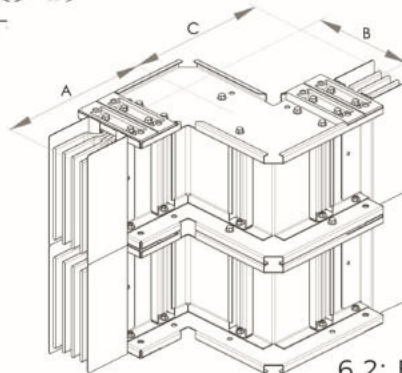

6.2: Edgewise Offset Elbow - DS

SANDWICH BUSWAY ELEMENTS

7. Flatwise Offset Elbow

Combines two flatwise elbows into one element for offset routing.

Standard Size (mm)			
Stack	A	B	C
SS	400	400	400
DS	500	500	500
TS	600	600	600

Min & Max arm Dimensions (mm)						
Stack	A		B		C	
	Min	Max	Min	Max	Min	Max
SS	400	800	200	800	400	800
DS	500	800	200	800	500	800
TS	600	800	200	800	600	600

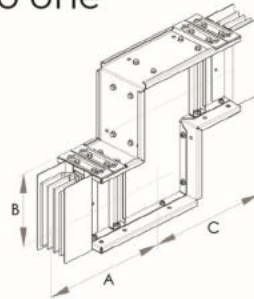

7.1: Flatwise Offset Elbow - SS

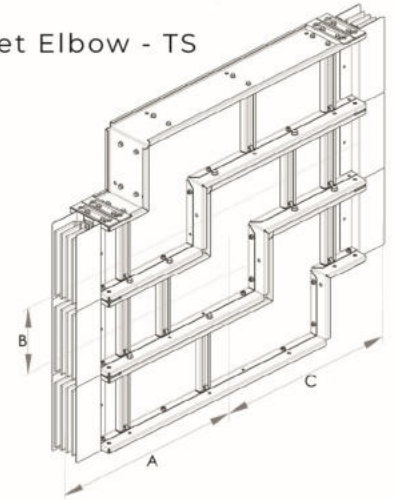

7.2: Flatwise Offset Elbow - DS

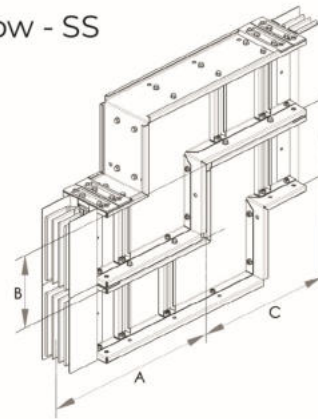

7.3: Flatwise Offset Elbow - TS

8. Combination Elbow

Combination of edgewise and flatwise elbows to meet routing needs. Includes arm dimension tables.

Standard Size (mm)			
Stack	A	B	C
SS	500	500	500
DS	500	500	500
TS	600	600	600

Min & Max arm Dimensions (mm)						
Stack	A		B		C	
	Min	Max	Min	Max	Min	Max
SS	400	1000	300	1000	400	1000
DS	500	1000	400	1000	500	1000
TS	600	1000	500	1000	600	1000

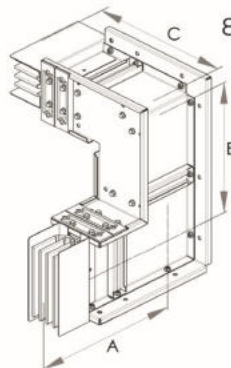

8.1: Combination Elbow - SS

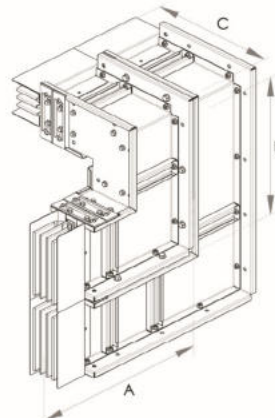

8.2: Combination Elbow - DS

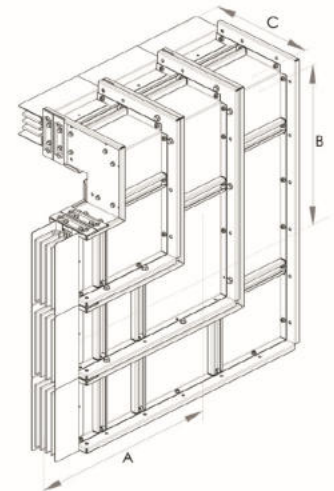

8.3: Combination Elbow - TS

9. Flatwise Tee

Used when a branch must extend perpendicular to the existing feeder run.

Standard Size (mm)			
Stack	A	B	C
SS	500	500	500

Min & Max arm Dimensions (mm)						
Stack	A		B		C	
	Min	Max	Min	Max	Min	Max
SS	400	1000	400	1000	400	1000

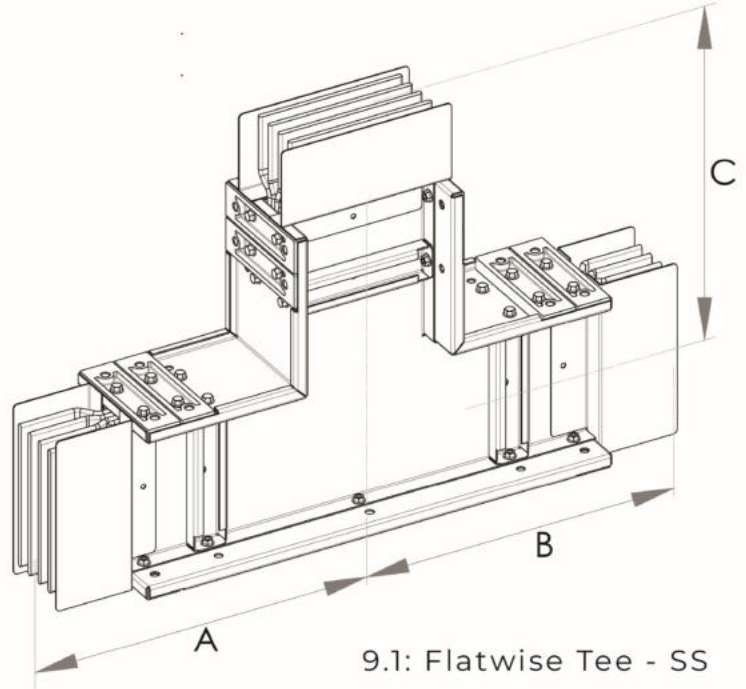

9.1: Flatwise Tee - SS

10. Phase-Crossover Unit

Used to change the phase orientation as required along the route.

Standard Size (mm)	
A	1500

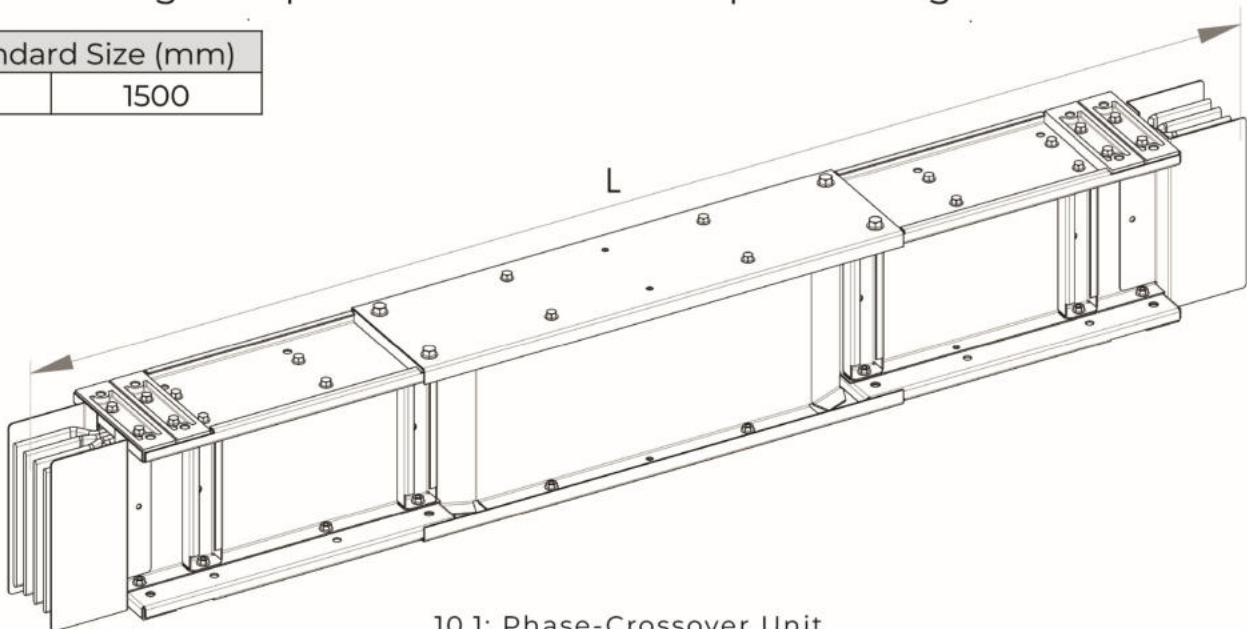

10.1: Phase-Crossover Unit

SANDWICH BUSWAY ELEMENTS

11. Expansion Unit

Used at every building expansion joint or every 40m of straight busduct run.

Standard Size (mm)	
A	1500

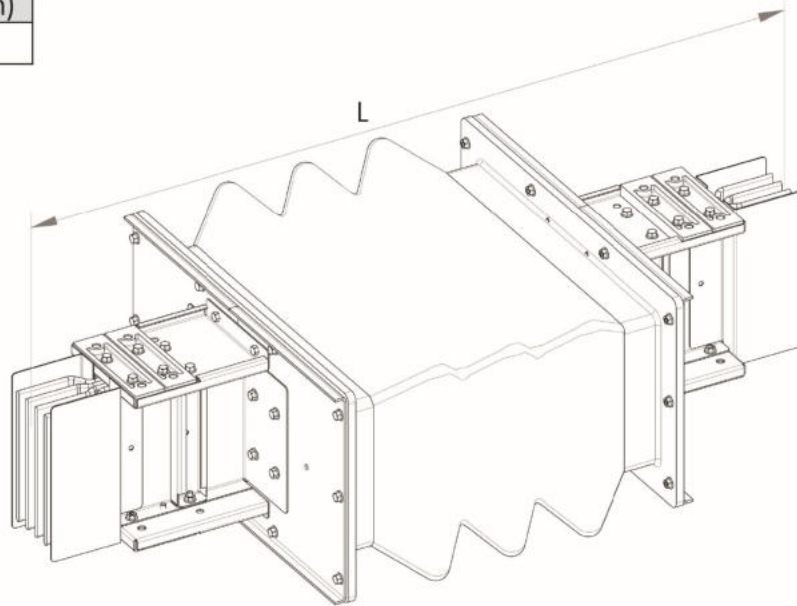

11.1: Expansion units

12. End Feed Unit

Used at the bottom or top of vertical risers fed by cables.

Rating	Aluminium – Without Isolator / Direct type					Copper – Without Isolator / Direct type				
	Dimensions(mm)					Dimensions(mm)				
	A	D	W	H	A	D	W	H		
400	500	1000	400	500	600	-				
630	500	1000	400	500	600	500	1000	400	500	600
800	500	1000	400	500	600	500	1000	400	500	600
1000	500	1000	400	500	600	500	1000	400	500	600
1250	500	1000	400	500	600	500	1000	400	500	600
1350	500	1000	400	500	600	-				
1600	500	1000	400	500	600	500	1000	400	500	600
2000	500	1000	400	500	600	500	1000	400	500	600
2500	600	1000	600	650	800	600	1000	400	500	600
2750	600	1000	600	650	800	600	1000	400	500	600
3200	600	1000	600	650	800	600	1000	600	650	800
4000	600	1000	Data on Request			600	1000	600	650	800
5000	800	1000	Data on Request			800	1000	600	650	800
6300	-					800	1000	Data on Request		

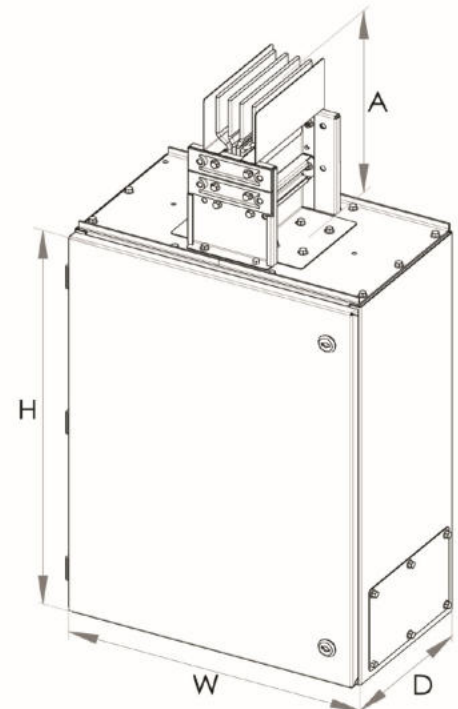

12.1 End Feed unit without Isolator

Rating	Aluminium – With Isolator					Copper – With Isolator				
	Dimensions(mm)					Dimensions(mm)				
	A		D	W	H	A		D	W	H
	Min.	Max.				Min.	Max.			
400	500	1000	400	500	800	-	-	-	-	-
630	500	1000	400	500	800	500	1000	400	500	1000
800	500	1000	400	500	800	500	1000	400	500	1000
1000	500	1000	400	500	1000	500	1000	400	500	1000
1250	500	1000	400	500	1000	500	1000	400	500	1000
1350	500	1000	400	500	1000	-				
1600	Data on Request					500	1000	400	500	1000
2000	Data on Request					Data on Request				
2500	Data on Request					Data on Request				
2750	Data on Request					Data on Request				
3200	Data on Request					Data on Request				
4000	Data on Request					Data on Request				
5000	Data on Request					Data on Request				
6300	-					Data on Request				

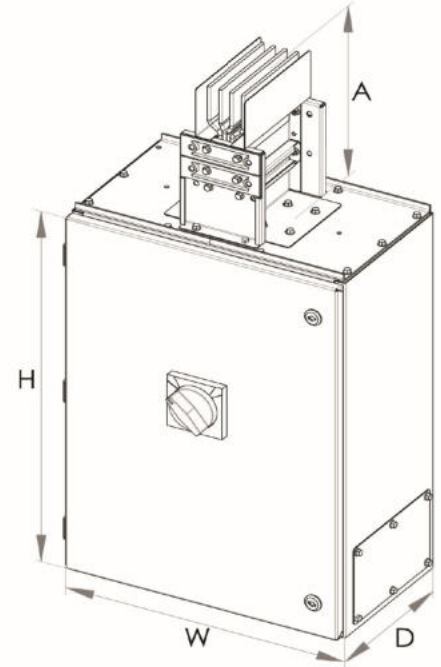

12.2: End Feed unit with Isolator

13. Center Feed Unit

Installed in the middle of a run for cable feeding.

With/without switchgear.

Without Isolator (Direct Type)

Rating	Aluminium – Without Isolator / Direct type					Copper – Without Isolator / Direct type				
	Dimensions(mm)					Dimensions(mm)				
	A		D	W	H	A		D	W	H
	Min.	Max.				Min.	Max.			
400	500	500	400	500	800	-				
630	500	500	400	500	800	500	500	400	500	600
800	500	500	400	500	800	500	500	400	500	600
1000	500	500	400	500	800	500	500	400	500	600
1250	500	500	400	500	800	500	500	400	500	600
1350	500	500	400	500	1000	-	-	-	-	-
1600	500	500	400	500	1000	500	500	400	500	1000
2000	500	500	400	500	1000	500	500	400	500	1000
2500	500	500	600	650	1000	500	500	400	500	1000
2750	500	500	600	650	1000	500	500	400	500	1000
3200	500	500	600	650	1000	500	500	600	650	1000
4000	500	500	Data on Request			500	500	600	650	1000
5000	500	500	Data on Request			500	500	600	650	1000
6300	-	-	-			500	500	600	650	1000

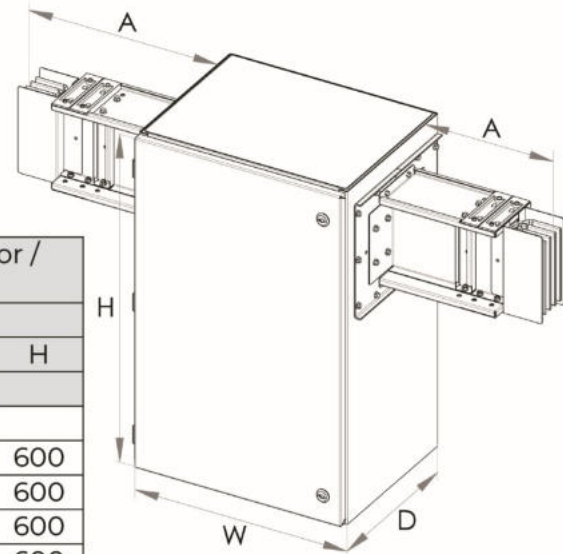

13.1: Center Feed units – Without Isolator / Direct type

SANDWICH BUSWAY ELEMENTS

Installed in the middle of a run for cable feeding.
With/without switchgear.

With Isolator (Direct Type)

Rating	Aluminium – With Isolator					Copper – With Isolator				
	Dimensions(mm)					Dimensions(mm)				
	A		D	W	H	A		D	W	H
	Min.	Max.				Min.	Max.			
400	500	500	400	500	1000	-				
630	500	500	400	500	1000	500	500	400	500	1000
800	500	500	400	500	1000	500	500	400	500	1000
1000	500	500	400	500	1000	500	500	400	500	1000
1250	500	500	400	500	1000	500	500	400	500	1000
1350	500	500	400	500	1000	-				
1600	Data on Request					500	1000	400	500	1000
2000	Data on Request					Data on Request				
2500	Data on Request					Data on Request				
2750	Data on Request					Data on Request				
3200	Data on Request					Data on Request				
4000	Data on Request					Data on Request				
5000	Data on Request					Data on Request				
6300	-					Data on Request				

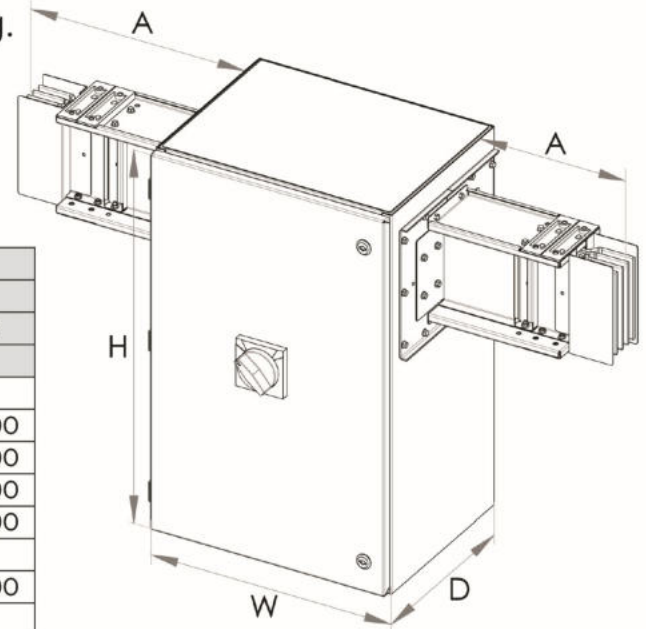

13.2: Center Feed units –
With Isolator /
Direct type

14. In-Line Isolator Unit

Provides isolation of a selected Busway section for maintenance or operational needs, and can be equipped with Load Break Switches (LBS), SFUs, or MCCBs for controlled switching and protection.

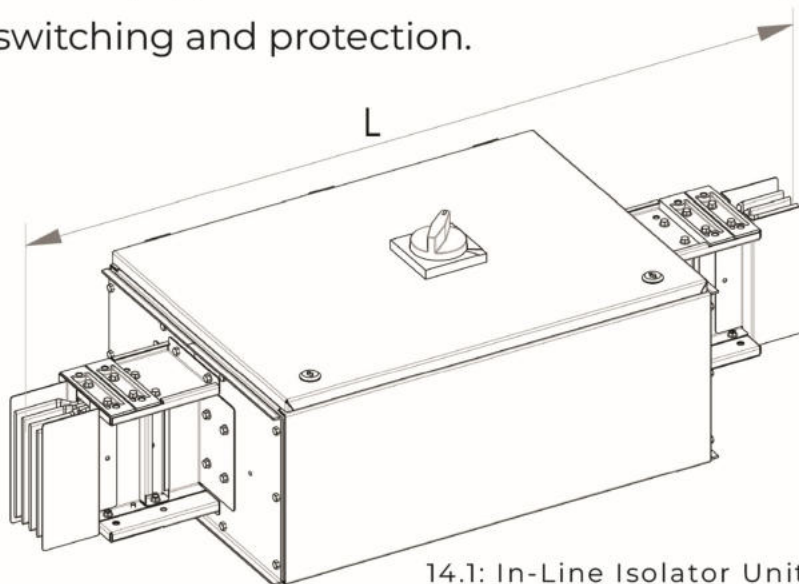

14.1: In-Line Isolator Unit

15. Reducer Unit

Used when reduction in ampere rating is required.

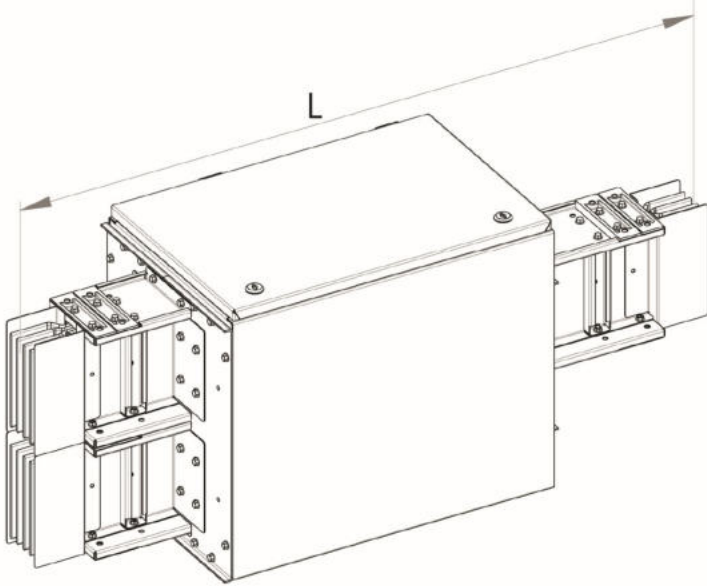

15.1: Reducer

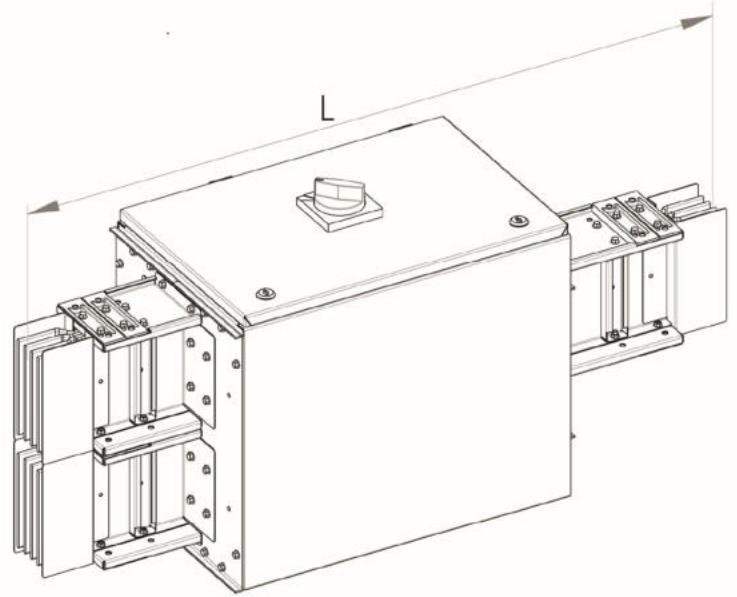

15.2: Reducer with Isolator

16. End Cap

Used to close the end of a busduct run.

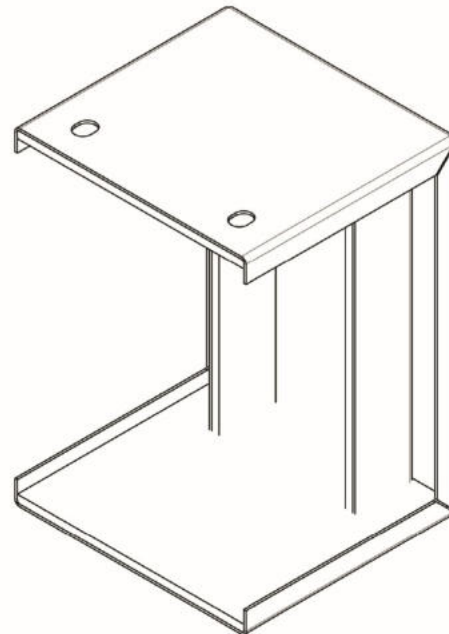

16.1: End Cap

SANDWICH BUSWAY ELEMENTS

17. Flange End

For direct connection with switchgear, transformers and electrical equipment.

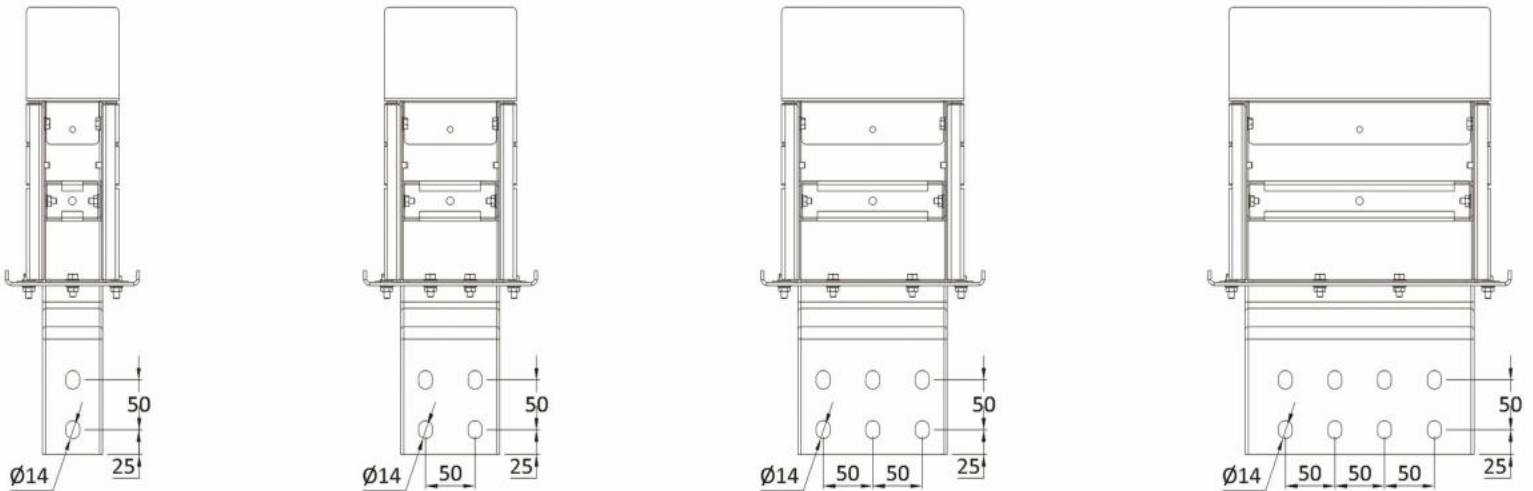

17.1: SS Flange End termination hole details-1

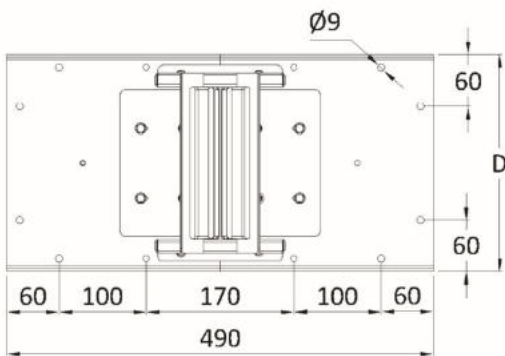

17.2: SS Flange End termination hole details-2

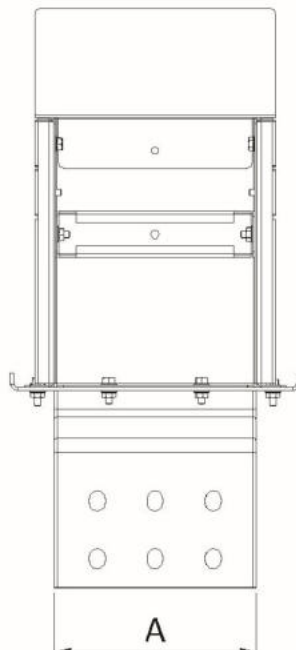
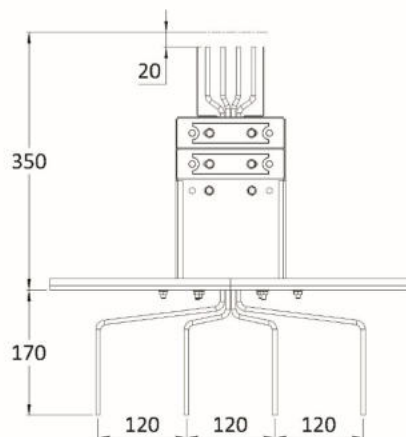

Stack	Busbar Width	A	D	E
SS	40	40	86	-
SS	50	50	96	-
SS	60	60	106	-
SS	70	70	116	-
SS	80	80	126	-
SS	100	100	146	-
SS	125	125	169	-
SS	150	150	219	-
SS	175	175	244	-
SS	200	200	269	-
SS	230	230	299	-
DS	125	285	331	-
DS	150	335	381	-
DS	175	385	431	-
DS	200	435	481	-
DS	230	495	541	-
TS	175	595	641	210
TS	200	670	716	235

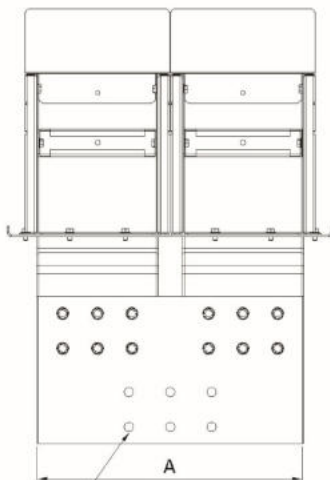
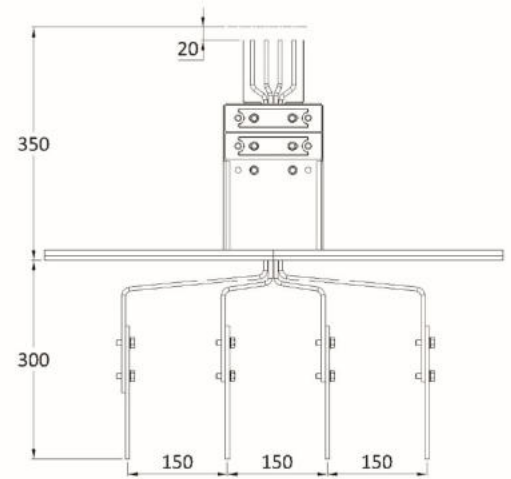
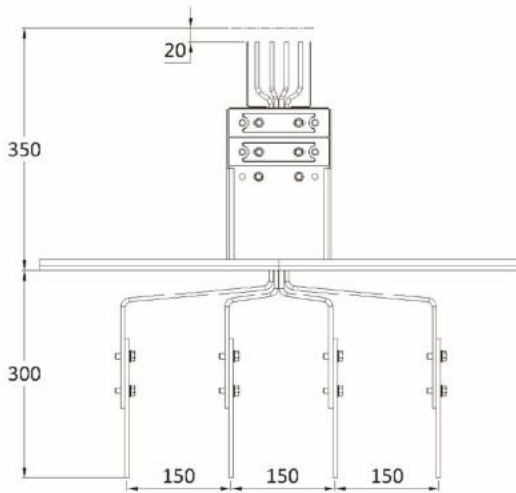
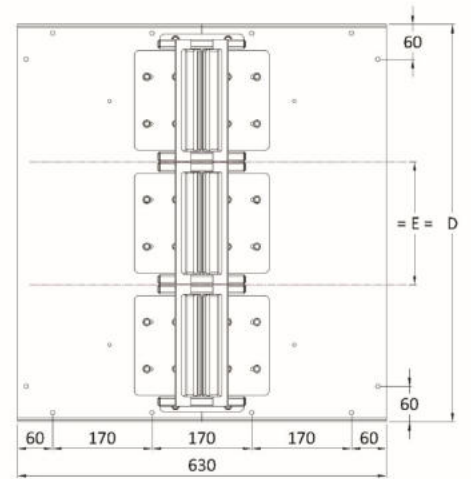
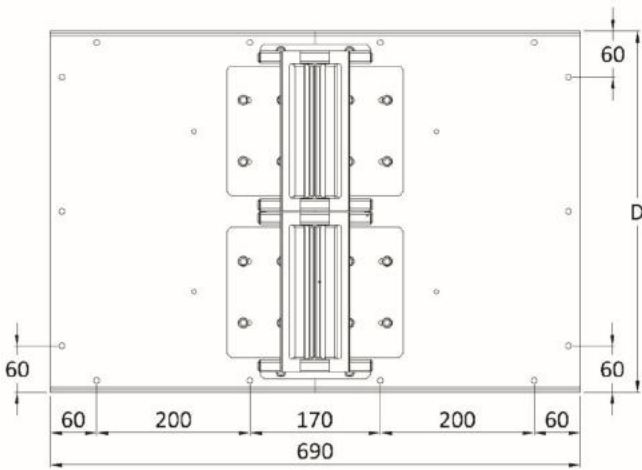

TERMINATION HOLES
($\phi 14$) AS PER REQUIREMENT

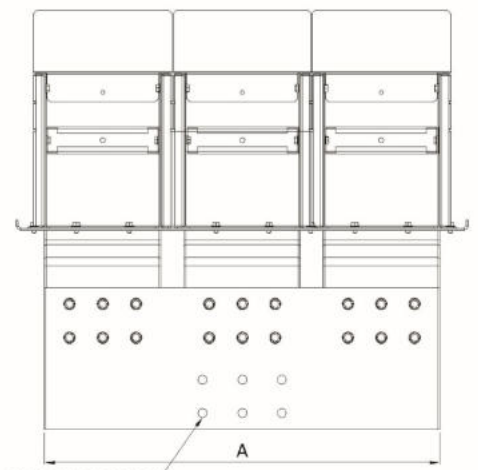

TERMINATION HOLES
($\phi 14$) AS PER REQUIREMENT

17.3: DS Flange End termination hole details

17.4: TS Flange End termination hole details

SANDWICH BUSWAY ELEMENTS

18. Flange End & Elbow Combinations

Flange End with Edgewise Elbow

Dimensions (mm)						
Stack	Standard		Max & Min Dimension			
	A	B	A		B	
			Min	Max	Min	Max
SS	500	500	400	600	400	1000
DS	600	600	500	700	500	1000
TS	800	800	700	900	700	1000

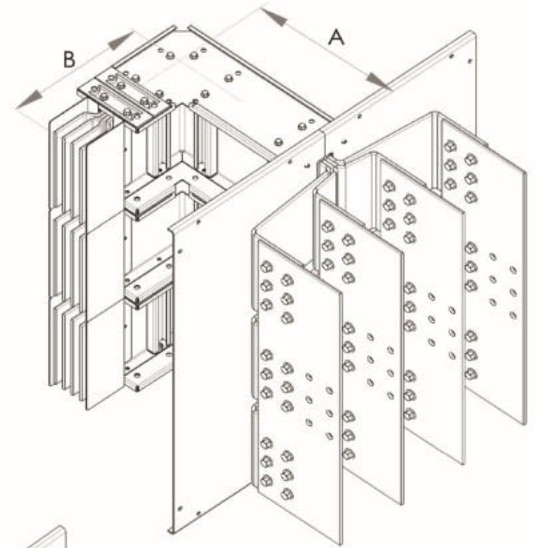

18.3: Flange End with Edgewise Elbow - TS

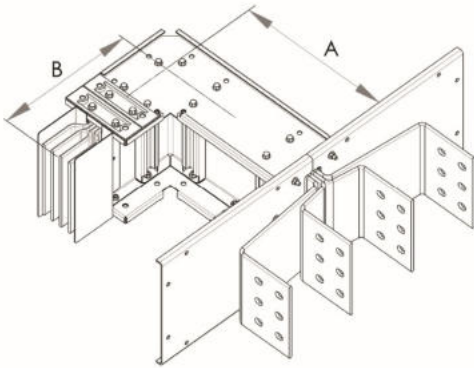

18.1: Flange End with Edgewise Elbow - SS

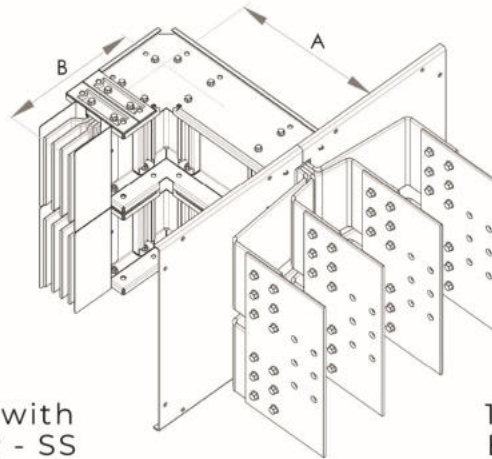

18.2: Flange End with Edgewise Elbow - DS

Flange End with Flatwise Elbow

Dimensions (mm)						
Stack	Standard		Max & Min Dimension			
	A	B	A		B	
			Min	Max	Min	Max
SS	500	500	400	600	400	1000
DS	600	600	500	700	500	1000
TS	800	800	700	900	700	1000

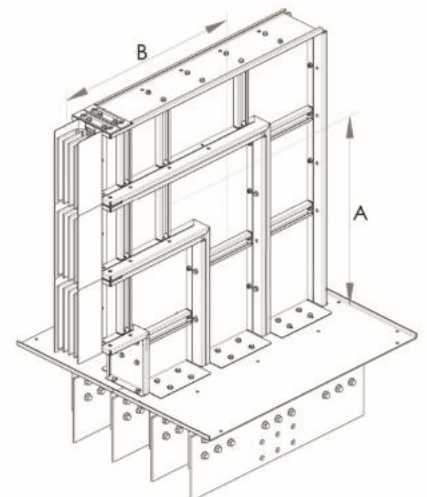

18.6: Flange End with Flatwise Elbow - TS

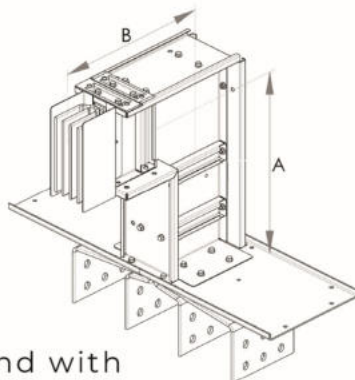

18.4: Flange End with Flatwise Elbow - SS

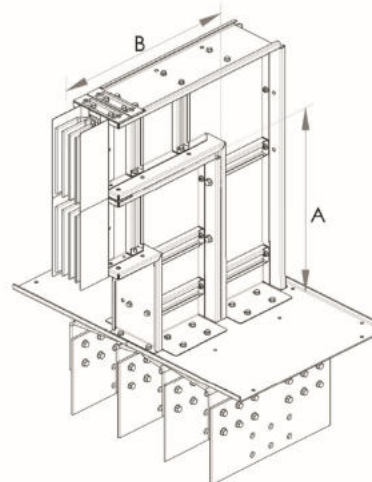

18.5: Flange End with Flatwise Elbow - DS

19. Adaptor Box

Customized housing between Flange End terminals and switchgear/transformer.

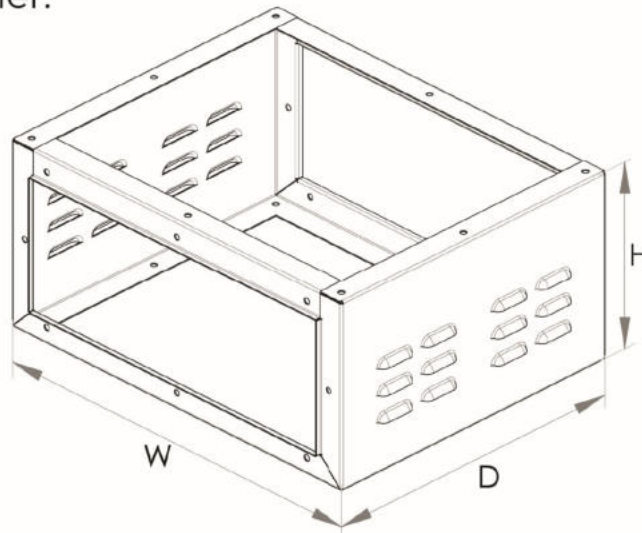

19.1: Adaptor box detail

20. Rubber Bellow

Installed between DG adaptor box and flange to isolate vibration.

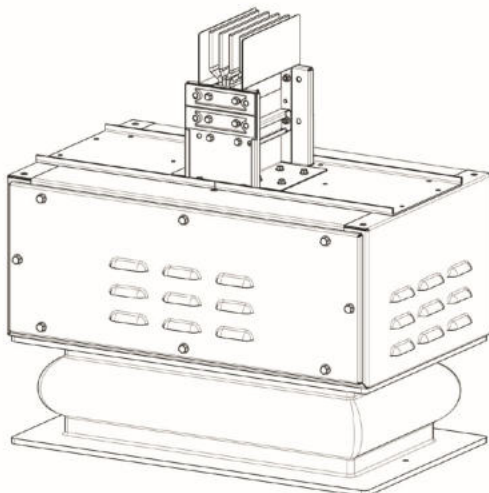

20.1 Rubber bellow mounting arrangement - SS

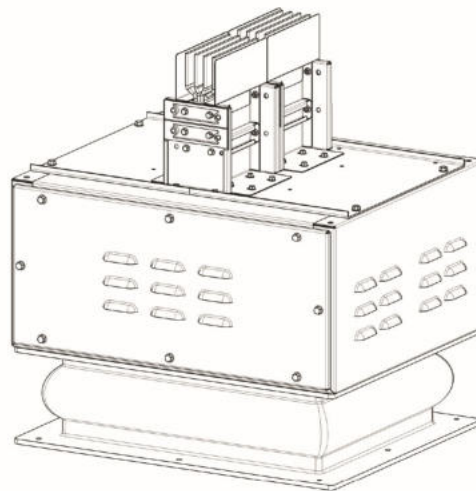

20.2 Rubber bellow mounting arrangement - DS

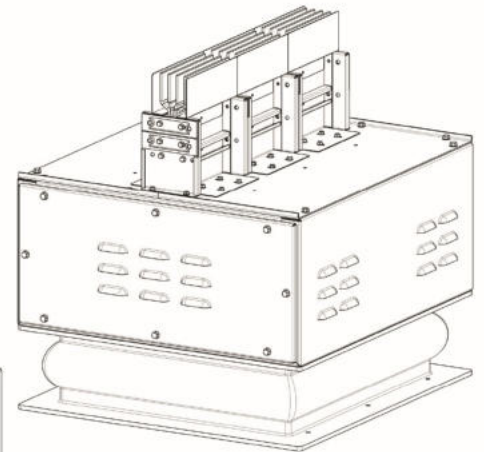

20.3 Rubber bellow mounting arrangement - TS

SANDWICH BUSWAY ELEMENTS

21. Flexible Connections

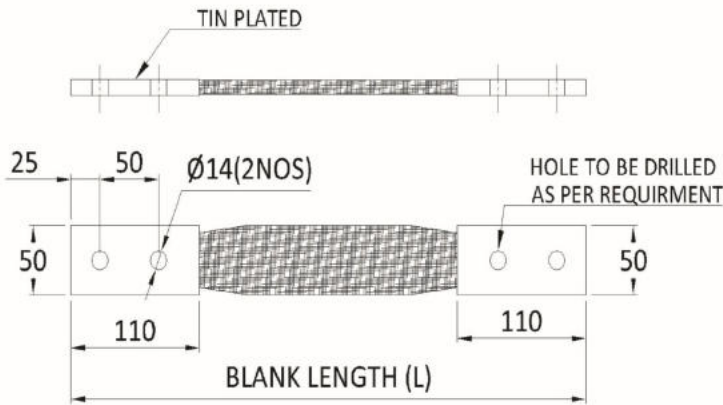

BRAIDED COPPER FLEXIBLE

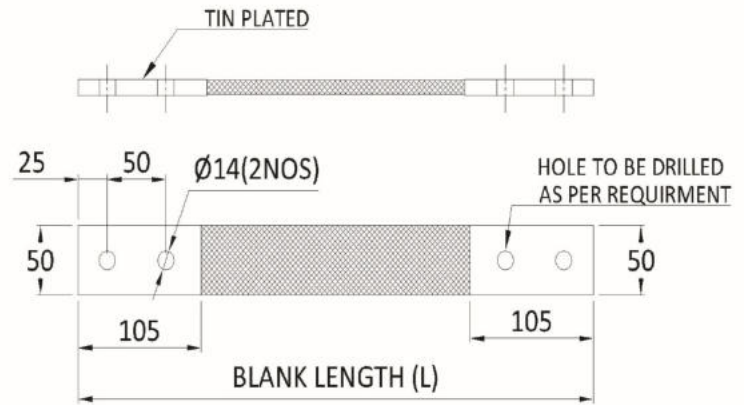

LAMINATED COPPER FLEXIBLE

21.1: Flexible copper detail

22. Tap off Boxes

Used to draw power from Plug in Points of plug in Feeders

Type	TOU-A	TOU-B	TOU-C	TOU-D
Rating	32 - 125A	160 - 250A	315 - 400A	500 - 630A
Box Size (LxWxH)	400x250x220	500x300x250	600x300x250	800x400x300

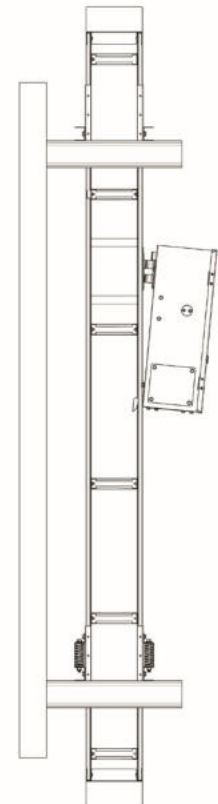

22.1: Tap off Boxes

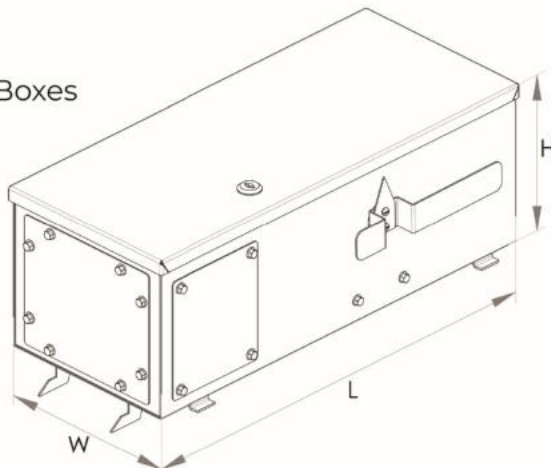

22.2: Tap off Boxes fixing Details

23. Vertical Rigid Hanger

One rigid hanger fixed per raising main

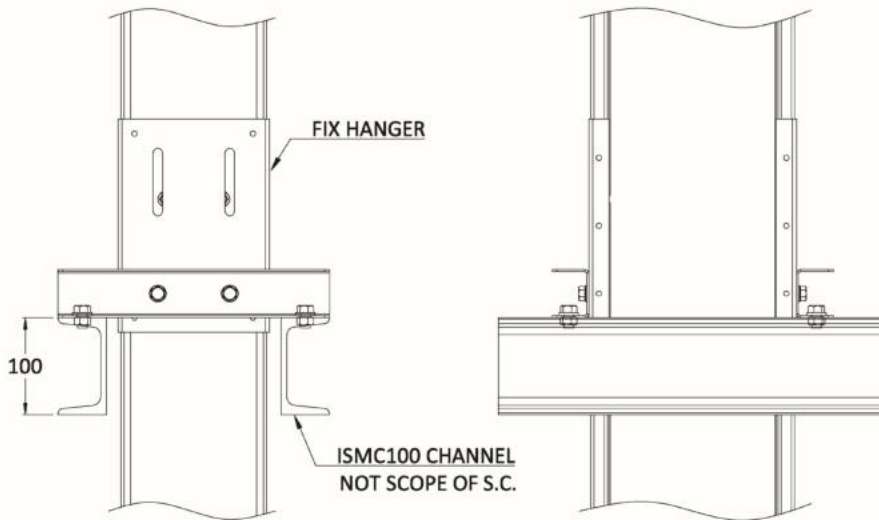

23.1: Rigid hanger Details

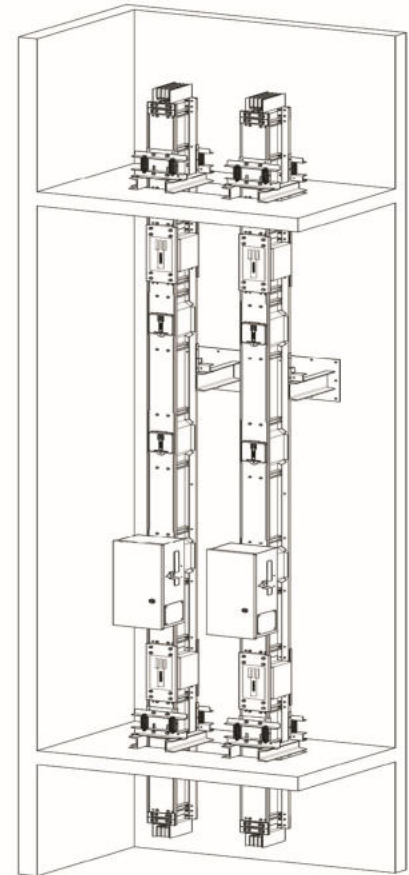

23.2: Spring hanger & Rigid Hanger Mounting arrangement detail

24. Vertical Spring Hanger

One hanger at every floor crossing. Supports vertical risers with spring action.

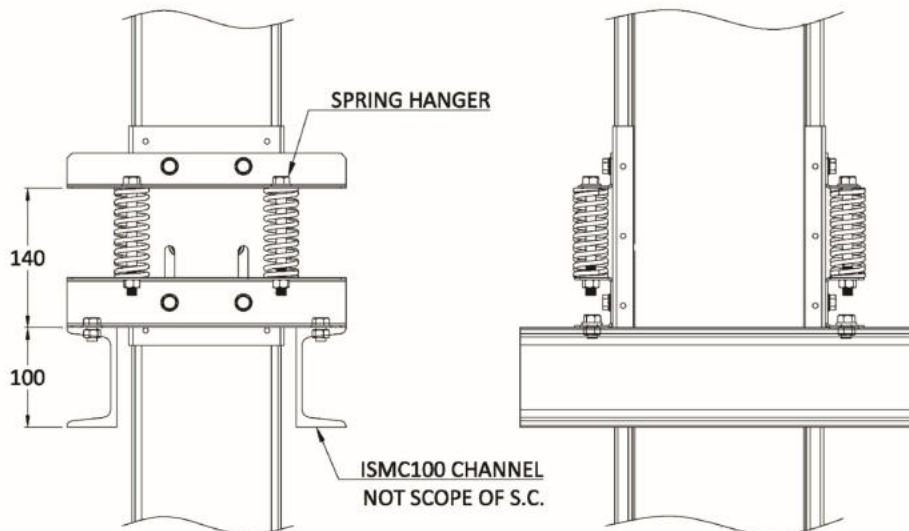

24.1: Spring hanger Details

SANDWICH BUSWAY ELEMENTS

25. Vertical Support

Vertical supports restrain lateral movement and maintain alignment of rising mains at each floor.

- Provided at every floor level
- Used with rigid or spring hangers
- Suitable for all sandwich busbar ratings
- Installed approximately 2 m above floor level

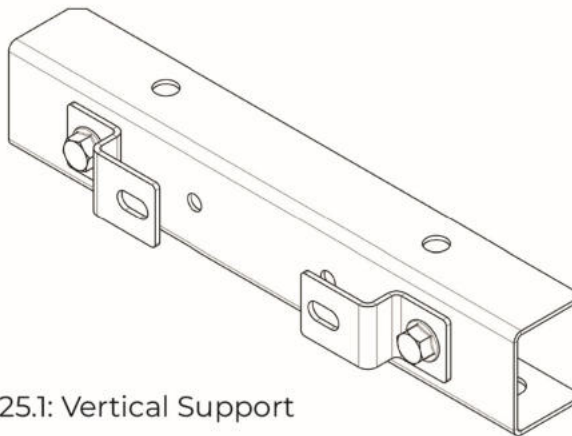

25.1: Vertical Support

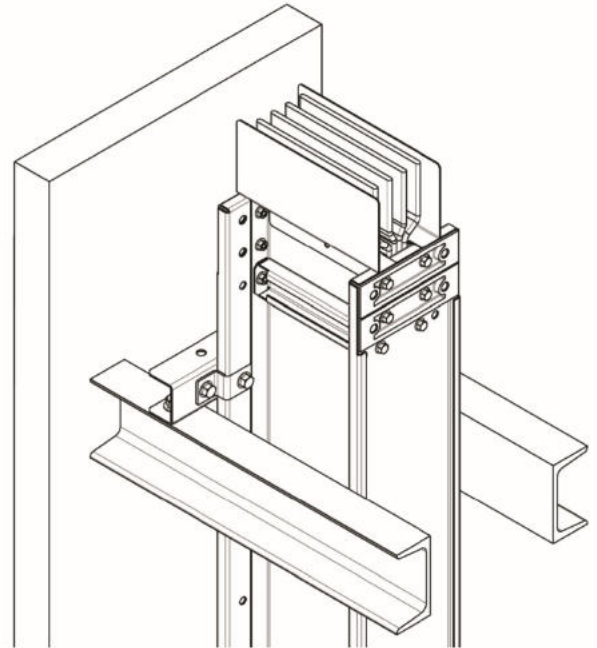

25.2: Vertical Support

26. Edgewise Horizontal Support

Required for Edgewise Horizontal Feeder Run and Recommended at an interval of 1.5meter

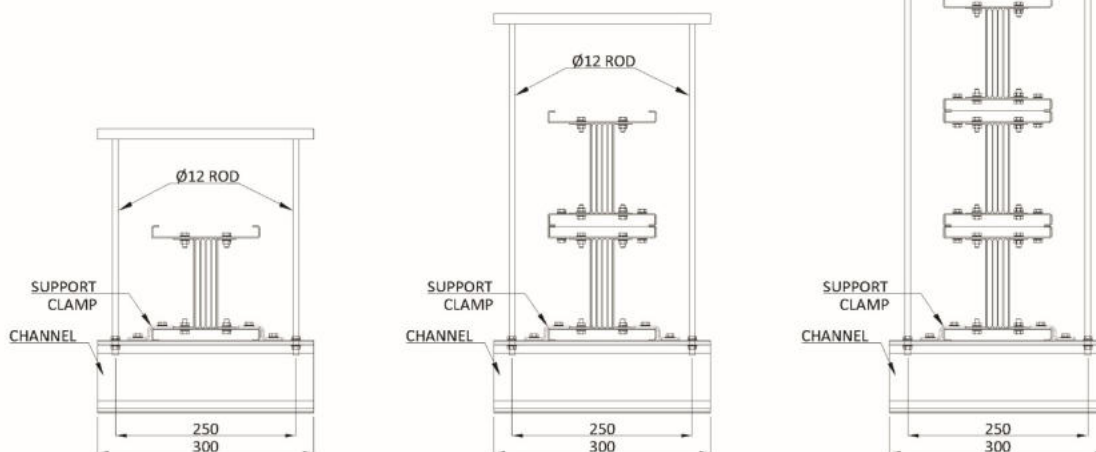

26.1: Edgewise Horizontal Support

27. Flatwise Horizontal Support

Required for Flatwise Horizontal Feeder Run and Recommended at an interval of 1.5meter

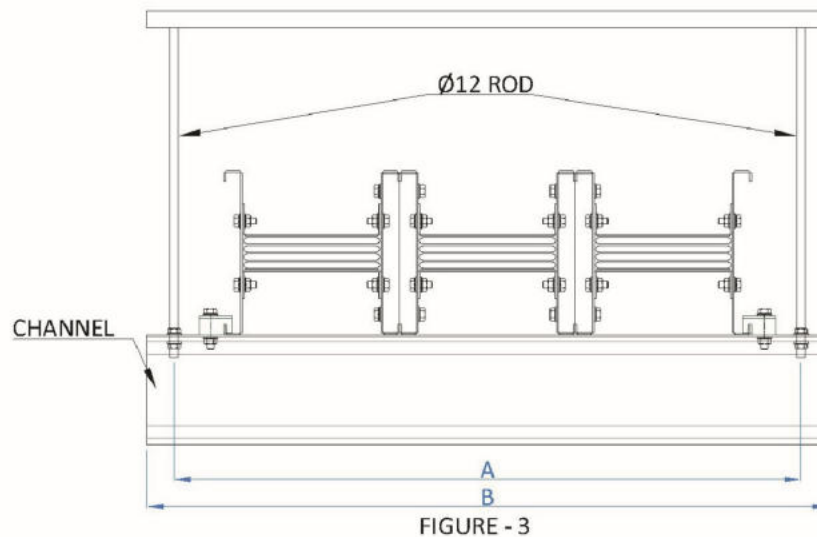
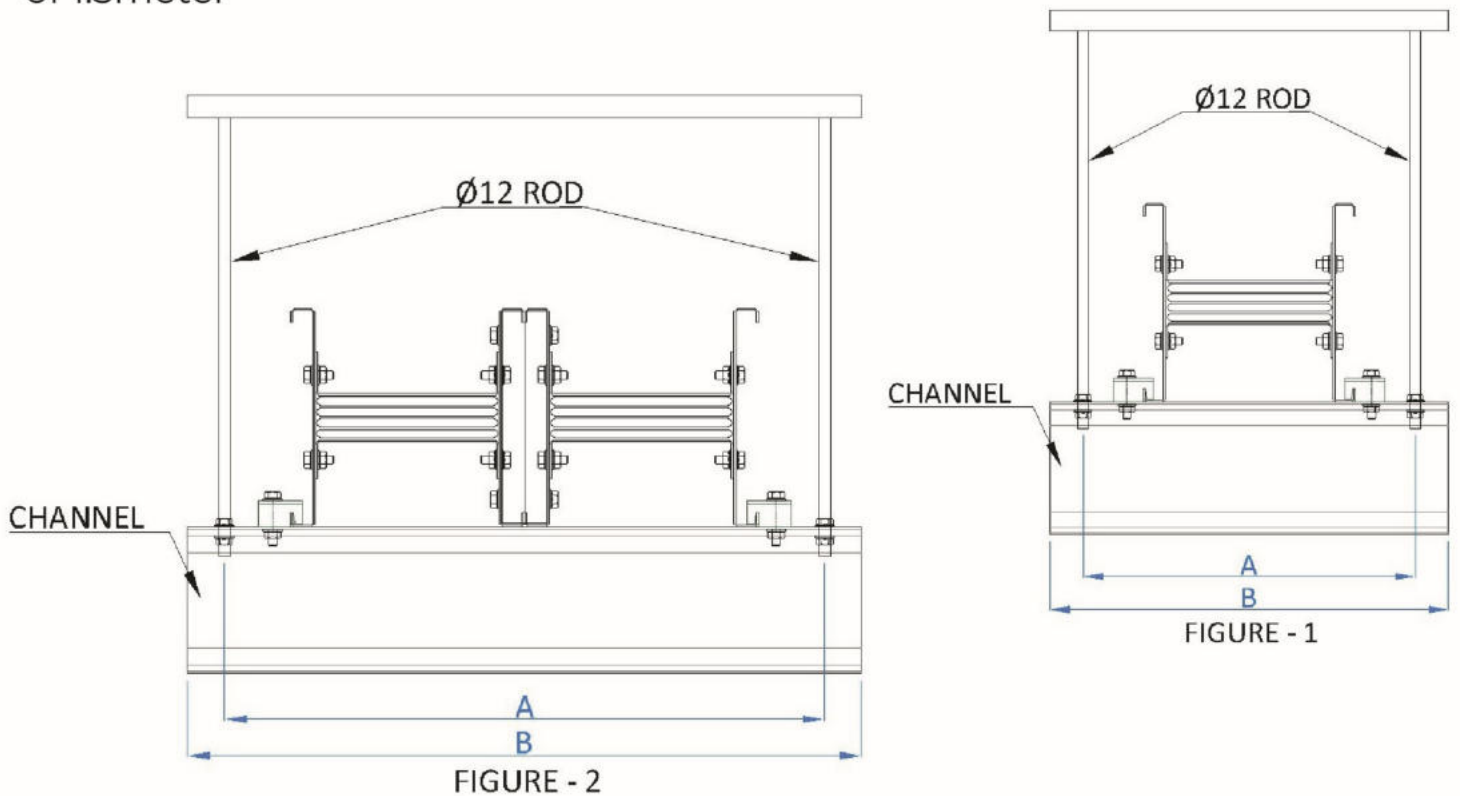

27.1: Flatwise Horizontal Support



BUSBAR TRUNKING SYSTEMS

We provide **end-to-end support**, including:

- On-site installation, erection & commissioning
- Execution through trained, authorized partners
- Quick response with **readily available critical spares**

Our experienced teams ensure **smooth execution, minimal downtime, and long-term reliability.**

Contact Us :

Phone : 9488189406 /07
Website : www.trishulbbt.in
Email : sales@trishulbbt.in
Address : 379, Anna Nagar,
Utharappan Kadu,
Maniyanur,
Salem - 636010,
Tamilnadu



Powering Reliability. Delivering Performance.

BUSBAR TRUNKING SYSTEMS